



enocean[®] alliance

No Wires. No Batteries. No Limits.

EnOcean Equipment Profiles (EEP)

Version: **2.1** - Jan. 20, 2011

Published by
EnOcean Alliance – Technical Task Group Interoperability
2400 Camina Ramon, Suite 375
San Ramon, CA 94583
USA

<http://www.enocean-alliance.org>
info@enocean-alliance.org

© EnOcean Alliance
All Rights Reserved

Copyright © EnOcean Alliance Inc. (2011). All rights Reserved.

EnOcean Alliance Inc.
2400 Camino Ramon, Suite 375
San Ramon, CA 94583
USA

Graham Martin
Chairman & CEO EnOcean Alliance These errata may not have been subjected to an
Intellectual Property review, and as such, may contain undeclared Necessary Claims.

www.enocean-alliance.org
Tel: (Germany Office) +49 89 67 34 689-646
Tel: (US Alliance Office) +1 925 275 6601
Tel: (Mobile)+49 151 12 52 5576

Table of content

1. Introduction

1. Terms, Abbreviations
2. General
3. What's new in EEP 2.1 ?
4. Telegram types (RORG)
5. EEP 2.1 modifications at RPS and 1BS data telegram
6. Structure and addressing of the telegram types
 1. RPS / 1BS
 2. 4BS
 3. VLD
7. Teach-in procedures
8. Viewing XML-data

2. Telegrams

1. F6: RPS Telegram

1. F6-02: Rocker Switch, 2 Rocker
 - F6-02-01: Light and Blind Control - Application Style 1
 - F6-02-02: Light and Blind Control - Application Style 2
2. F6-03: Rocker Switch, 4 Rocker
 - F6-03-01: Light and Blind Control - Application Style 1
 - F6-03-02: Light and Blind Control - Application Style 2
3. F6-04: Position Switch, Home and Office Application
 - F6-04-01: Key Card Activated Switch
4. F6-10: Mechanical Handle
 - F6-10-00: Window Handle

2. D5: 1BS Telegram

1. D5-00: Contacts and Switches
 - D5-00-01: Single Input Contact

3. A5: 4BS Telegram

1. A5-02: Temperature Sensors
 - A5-02-01: Temperature Sensor Range -40°C to 0°C
 - A5-02-02: Temperature Sensor Range -30°C to +10°C
 - A5-02-03: Temperature Sensor Range -20°C to +20°C
 - A5-02-04: Temperature Sensor Range -10°C to +30°C
 - A5-02-05: Temperature Sensor Range 0°C to +40°C
 - A5-02-06: Temperature Sensor Range +10°C to +50°C
 - A5-02-07: Temperature Sensor Range +20°C to +60°C
 - A5-02-08: Temperature Sensor Range +30°C to +70°C
 - A5-02-09: Temperature Sensor Range +40°C to +80°C
 - A5-02-0A: Temperature Sensor Range +50°C to +90°C
 - A5-02-0B: Temperature Sensor Range +60°C to +100°C
 - A5-02-10: Temperature Sensor Range -60°C to +20°C
 - A5-02-11: Temperature Sensor Range -50°C to +30°C
 - A5-02-12: Temperature Sensor Range -40°C to +40°C
 - A5-02-13: Temperature Sensor Range -30°C to +50°C
 - A5-02-14: Temperature Sensor Range -20°C to +60°C
 - A5-02-15: Temperature Sensor Range -10°C to +70°C
 - A5-02-16: Temperature Sensor Range 0°C to +80°C
 - A5-02-17: Temperature Sensor Range +10°C to +90°C
 - A5-02-18: Temperature Sensor Range +20°C to +100°C
 - A5-02-19: Temperature Sensor Range +30°C to +110°C
 - A5-02-1A: Temperature Sensor Range +40°C to +120°C
 - A5-02-1B: Temperature Sensor Range +50°C to +130°C
 - A5-02-20: 10 Bit Temperature Sensor Range -10°C to +41.2°C
 - A5-02-30: 10 Bit Temperature Sensor Range -40°C to +62.3°C
2. A5-04: Temperature and Humidity Sensor
 - A5-04-01: Range 0°C to +40°C and 0% to 100%
3. A5-06: Light Sensor
 - A5-06-01: Range 300lx to 60.000lx
 - A5-06-02: Range 0lx to 1.020lx
4. A5-07: Occupancy Sensor
 - A5-07-01: Occupancy
5. A5-08: Light, Temperature and Occupancy Sensor
 - A5-08-01: Range 0lx to 510lx, 0°C to +51°C and Occupancy
 - A5-08-02: Range 0lx to 1020lx, 0°C to +51°C and Occupancy
 - A5-08-03: Range 0lx to 1530lx, -30°C to +50°C and Occupancy
6. A5-09: Gas Sensor
 - A5-09-01: CO Sensor (tbd!)

- A5-09-04: CO2 Sensor
 - 7. A5-10: Room Operating Panel
 - A5-10-01: Temperature Sensor, Set Point, Fan Speed and Occupancy Control
 - A5-10-02: Temperature Sensor, Set Point, Fan Speed and Day/Night Control
 - A5-10-03: Temperature Sensor, Set Point Control
 - A5-10-04: Temperature Sensor, Set Point and Fan Speed Control
 - A5-10-05: Temperature Sensor, Set Point and Occupancy Control
 - A5-10-06: Temperature Sensor, Set Point and Day/Night Control
 - A5-10-07: Temperature Sensor, Fan Speed Control
 - A5-10-08: Temperature Sensor, Fan Speed and Occupancy Control
 - A5-10-09: Temperature Sensor, Fan Speed and Day/Night Control
 - A5-10-0A: Temperature Sensor, Set Point Adjust and Single Input Contact
 - A5-10-0B: Temperature Sensor and Single Input Contact
 - A5-10-0C: Temperature Sensor and Occupancy Control
 - A5-10-0D: Temperature Sensor and Day/Night Control
 - A5-10-10: Temperature and Humidity Sensor, Set Point and Occupancy Control
 - A5-10-11: Temperature and Humidity Sensor, Set Point and Day/Night Control
 - A5-10-12: Temperature and Humidity Sensor and Set Point
 - A5-10-13: Temperature and Humidity Sensor, Occupancy Control
 - A5-10-14: Temperature and Humidity Sensor, Day/Night Control
 - A5-10-15: 10 Bit Temperature Sensor, 6 bit Set Point Control
 - A5-10-16: 10 Bit Temperature Sensor, 6 bit Set Point Control; Occupancy Control
 - A5-10-17: 10 Bit Temperature Sensor, Occupancy Control
 - A5-10-18: Illumination, Temperature Set Point, Temperature Sensor, Fan Speed and Occupancy Control (Not approved)
 - A5-10-19: Humidity, Temperature Set Point, Temperature Sensor, Fan Speed and Occupancy Control (Not approved)
 - A5-10-1A: Supply voltage monitor, Temperature Set Point, Temperature Sensor, Fan Speed and Occupancy Control (Not approved)
 - A5-10-1B: Supply Voltage Monitor, Illumination, Temperature Sensor, Fan Speed and Occupancy Control (Not approved)
 - A5-10-1C: Illumination, Illumination Set Point, Temperature Sensor, Fan Speed and Occupancy Control (Not approved)
 - A5-10-1D: Humidity, Humidity Set Point, Temperature Sensor, Fan Speed and Occupancy Control (Not approved)
 - A5-10-1E: Supply Voltage Monitor, Illumination, Temperature Sensor, Fan Speed and Occupancy Control (Not approved)
 - 8. A5-11: Controller Status
 - A5-11-01: Lighting Controller
 - A5-11-02: Temperature Controller Output (Not approved)
 - 9. A5-12: Automated meter reading (AMR)
 - A5-12-00: Counter
 - A5-12-01: Electricity
 - A5-12-02: Gas
 - A5-12-03: Water
 - 10. A5-13: Environmental Applications
 - A5-13-01: Weather Station
 - A5-13-02: Sun Intensity, Northern Hemisphere
 - A5-13-03: Date Exchange
 - A5-13-04: Time and Day Exchange
 - A5-13-05: Direction Exchange
 - A5-13-06: Geographic Position Exchange
 - 11. A5-20: HVAC Components
 - A5-20-01: Battery Powered Actuator (Submitted by K+P) (BI-DIR)
 - A5-20-02: Basic Actuator (Submitted by Spartan) (BI-DIR)
 - A5-20-03: Line powered Actuator (Submitted by Spartan) (BI-DIR)
 - A5-20-10: Generic HVAC Interface (Submitted by Intesis) (BI-DIR)
 - A5-20-11: Generic HVAC Interface – Error Control (Submitted by Intesis) (BI-DIR)
 - A5-20-12: Temperature Controller Input
 - 12. A5-30: Digital Input
 - A5-30-01: Single Input Contact, Battery Monitor
 - A5-30-02: Single Input Contact
 - 13. A5-37: Energy Management
 - A5-37-01: Demand Response
 - 14. A5-38: Central Command
 - A5-38-08: PHC Gateway
 - 15. A5-3F: Universal
 - A5-3F-00: Radio Link Test (BI-DIR)
- 4. D2: VLD Telegram**
1. D2-00: Room Control Panel (RCP)
 - D2-00-01: RCP with Temperature Measurement and Display (BI-DIR)

3. Appendix

1. RPS Teach-in
2. 1BS Teach-in

3. 4BS Teach-in
4. Smart Ack Teach-in (without repeater)
5. Smart Ack Teach-in (with repeater)
6. XML + DOC Maintenance process
 1. General
 2. XML file
7. Smart Ack: functional principle (without repeater)
8. Smart Ack: functional principle (with repeater)
9. Remote Management / RPC
10. Existing 'bidirectional' profile structures
11. MSC telegram - Manufacturer Specific Communication
12. Use Cases for profile 2D-00-01 (self powered RCP for 2way operation)
13. Manufacturer ID's
14. Revision

1) Introduction

1.1) Terms, Abbreviations

1BS	EnOcean 1 Byte Communication
4BS	EnOcean 4 Byte Communication
Choice	Unique identification of EnOcean radio telegram types (RPS, 1BS, 4BS, ...); equivalent with RORG
Client	Bidirectional Smart Ack Device
Data	Payload of ERP telegrams or ESP packets
EEP	EnOcean Equipment Profiles
ERP	EnOcean Radio Protocol
ESP	EnOcean Serial Protocol
HTML	Hyper Text Markup Language; HTML can be displayed using a internet browser
MSC	Manufacturer Specific Communication
N/A	Not applicable
ORG	Organizational number for EnOcean radio telegram types (out-dated with EEP 2.1; used for ESP2 interface)
RORG	Radio ORG = organization number for EnOcean radio telegram types (new with EEP 2.1); equivalent with 'Choice'
RMCC	Remote Management Control Commands
RPC	Remote Procedure Calls
RPS	EnOcean telegram type for Repeated Switch Communication
Smart Ack	Smart Acknowledge EnOcean standard for energy-optimized bidirectional transmission
UART	Universal Asynchronous Receiver Transmitter
VLD	EnOcean Variable Length Data telegram
XML	Extensible Markup Language; designed to transport and store data
XSL	Extensible Stylesheet Language; XML based language to visualize XML (data)

1.2) General

The EnOcean radio protocol (ERP) is optimized to transmit information with utmost reliability using extremely little power while ensuring that the products of customers applying EnOcean technology are compatible with each other. Only the very shortest transmission period ($< 1\text{ms}$) for an EnOcean telegram allows the design of, for example, a battery-free radio switch, which can produce a full radio command with just approx. $50\ \mu\text{Ws}$ ($50\ \mu\text{J}$) of energy. At the same time, the reliability of the system increases, as the possibility of data collision is strongly reduced. Every data bit in the radio telegram is essential. For each '0' or '1' state, content descriptions are defined, which must be followed by the sender and the receiver likewise. Depending on the telegram type and the function of the device the user data (payload) is defined in:

EEP (EnOcean Equipment Profiles)

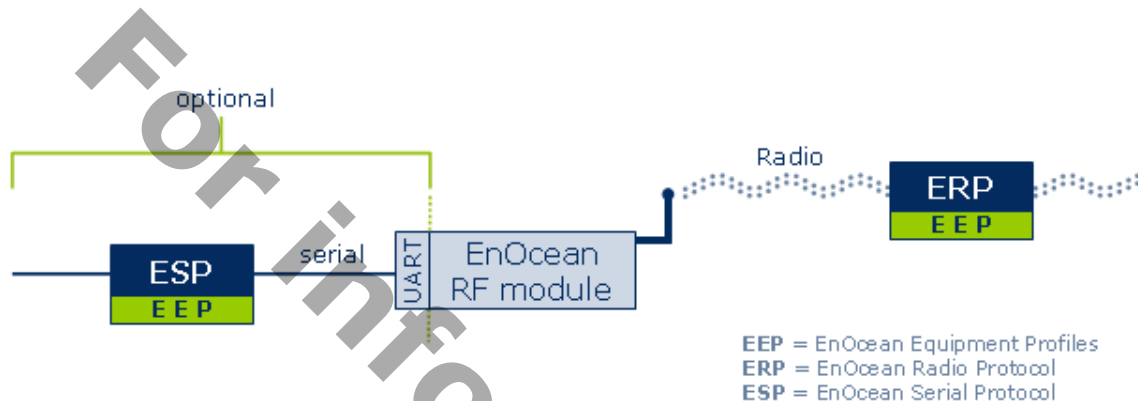

The ERP specification defines the structure of the entire radio telegram. The user data embedded in this structure is defined by the EEP.

The objective of interoperability is easier to reach with as less profiles as required. Therefore, it is EnOcean Alliance's goal to configure each profile as universally as possible, to target a spectrum of devices in the building automation sector for all manufacturers.

It is of high interest to the EnOcean Alliance that Alliance members verify new devices or newly joined companies verify their products against the existing EEP Profiles and adopt these during testing. Every newly defined EEP would increase diversity and therefore decrease interoperability.

The technical characteristics of a device define three profile elements, which make up the organizational description of all profiles:

1. The ERP radio telegram type (RORG)
2. Basic functionality of the data content (FUNC)
3. Type of device in its individual characteristics (TYPE)

Therefore, every EEP profile has a number, reflecting these three components:

EEP 2.0:	ORG	FUNC	TYPE
EEP 2.1:	RORG	FUNC	TYPE
Range (hex):	00 ... FF	00 ... 3F	00 ... 7F
	8 bit	6 bit	7 bit

Every field is represented by a hexadecimal number, where the maximum value is limited by the available bits.

Before the definition of a new profile existing profiles should be checked first for suitability. A new profile is to be

defined only if the existing profiles would not be adequate.

Once a new profile is to be developed it should be submitted to the TWG of the EnOcean Alliance. The information to be provided is

- the XML-data, plus
- the profile as text in a pdf-file (the .pdf-data is to be generated from the XML-data)

The TWG will review and ratify the profile. Following the recommendation by the TWG the BoD will disapprove or approve the profile.

When defining a new profile rules, abbreviations and terms as per this document have to be applied.

To maintain the XML-data and the linked pdf-document in a proper way a document maintenance process is defined. For details refer to appendix 3.6 Data + document maintenance process.

1.3) What's new in EEP 2.1 ?

The CHANGE

- Data (XML) is THE source of information; content is edited (= data) on XML-level with appropriate XML-editor.
- Viewing of XML-data via HTML-browser (optimised for Firefox ≥3.6)
- Printing best via .pdf
- XML-data can be transferred directly to code developed by partners
- However: consistency and sanity check is to be performed on product level as data errors can not be excluded
- For further details refer to appendix 3.6, please

Document consistency

- RORG instead of ORG for telegram types (for RPS-, 1BS- and 4BS telegrams) - to establish an orthogonal data structure across all application layers and interfaces.
- 1BS and RPS telegram: only DB0 as data byte (instead of DB0...3 with 3 unused bytes).

New 4 BS telegrams

- A5-02-20, -30 (10 bit temperature sensors)
- A5-09-04 (CO2 sensor)
- A5-10-15,-16,-17,-18,-19,-1A,-1B,-1C,-1D,-1E (Room operation panels)
- A5-11-02 (Temperature controller)
- A5-12-00,-01,-02,-03 (Automated meter reading)
- A5-13-01,-02,-03,-04,-05,-06 (Environmental applications)
- A5-20-01*, -02*, -03*, -10*, -11*, -12 (HVAC components)
- A5-37-01 (Energy management / demand response)
- A5-3F-00* (Radio link test)

New telegram type VLD

- D2-00-01 (Room control panel)*

New definitions and chapters

- Smart Ack
- Remote management (RPC)
- MSC telegram
- Bi-directional profiles (4 BS)

New data

- 15 new manufacturers (ID from 0x00D to 0x01C)

* = Bi-directional profiles

1.4) Telegram types (RORG)

The various **Radio-Telegram** types are grouped **organizationally**.

The specifications of ERP (EnOcean Radio Protocol) and of ESP (EnOcean Serial Protocol) group telegram types by 'CHOICE' number. 'RORG' at EEP 2.1 corresponds to 'CHOICE'.

The following RORG are used in EEP 2.1:

Telegram	RORG	ORG	
RPS	F6	05	Repeated Switch Communication
1BS	D5	06	1 Byte Communication
4BS	A5	07	4 Byte Communication
VLD	D2	=RORG	Variable Length Data
MSC	D1	=RORG	Manufacturer Specific Communication
ADT	A6	=RORG	Addressing Destination Telegram
SM_LRN_REQ	C6	=RORG	Smart Ack Learn Request
SM_LRN_ANS	C7	=RORG	Smart Ack Learn Answer
SM_REC	A7	=RORG	Smart Ack Reclaim
SYS_EX	C5	=RORG	Remote Management

For compatibility reasons, the old ORG values on the serial ESP2 interfaces remain valid. However, on the air interface, each ESP2 telegram is transported with the appropriate RORG (= CHOICE).

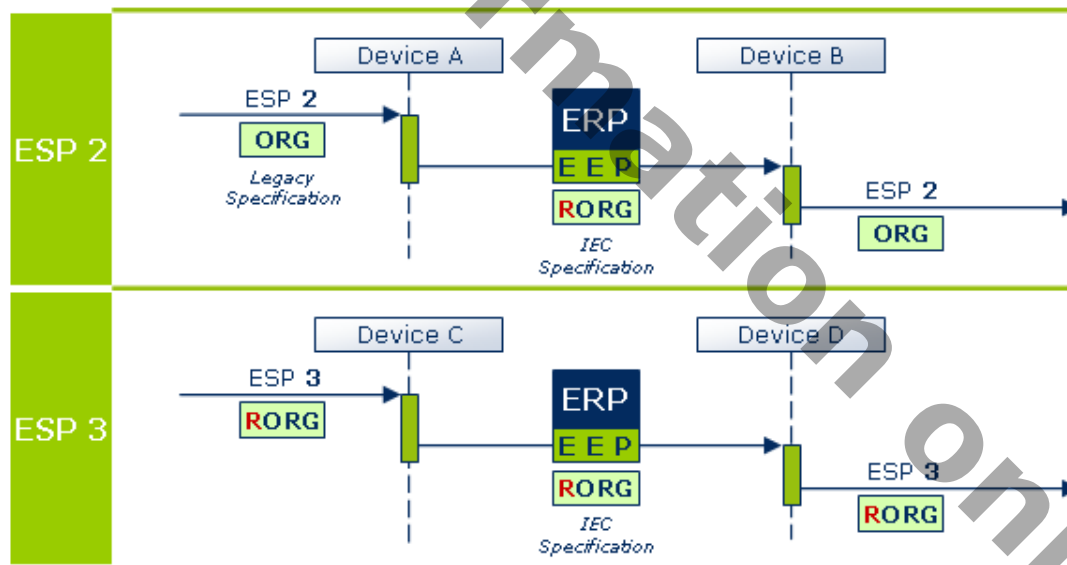

RORG ≠ CHOICE

EEP = EnOcean Equipment Profiles
 ERP = EnOcean Radio Protocol
 ESP = EnOcean Serial Protocol

1.5) EEP 2.1 modifications at RPS and 1BS data telegram

Both telegram types carry a one byte payload (DB_0) on the wireless interface (ERP).

EEP 2.0 follows the specification of the serial interface / ESP2, which defines the payload to be carried in DB_3 (see succeeding figure). The trailing bytes, DB_2, DB_1 and DB_0 are marked as 'unused'.

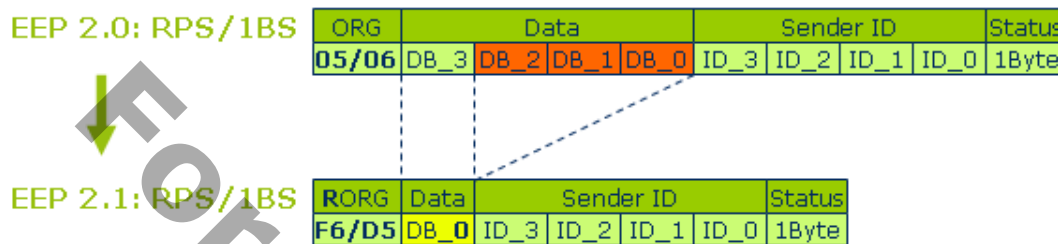

For orthogonal data structural reasons, this deviation will be avoided with EPP 2.1 and future versions. The new ESP3 serial interface already respects this.

For reasons of compatibility of end devices, the ESP2 interface remains unaltered, i.e. the DB_0 byte (radio) will continue to be transferred as a DB_3 byte (serial) (including the 3 unused bytes). The conversation has to happen on the application layer as the XML-data structure of EEP2.1 only refers to the DB_0 byte.

As a consequence of this modification the LRN bit is now described in a row for the 1BS and 4BS telegram types as standardized with the DB_0.BIT_3 position.

1.6) Structure and addressing of the telegram types

1.6.1) RPS / 1BS

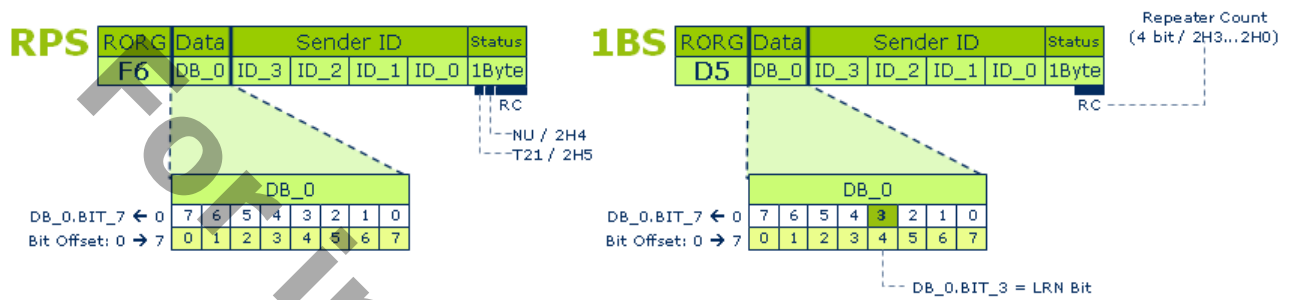

The RPS and the 1BS telegrams offer only 1 byte user data. These two telegrams differ in the respective learning operations (the 1BS has a LRN bit), and in the way the status byte is used.

1.6.2) 4BS

A 4BS telegram carries a payload of 4 bytes. The sequence of the 4 data bytes is historically reversed, so that DB_3 appears first and DB_0 last on the radio interface. The bits are addressed in the sequence of the data flow, however (offset). Hence, DB_3.BIT_7 has the offset position 0 and DB_0.BIT_3 (LRN bit) has the offset position 28. The actual content-bits in a byte are not affected by this, i.e., they are described from right (2H0) to left (2H7) in the ascending order.

The example of a 10-bit temperature profile (see below) illustrates the binary valuation of the individual bits, so that a number range from 0 ... 1023 can be addressed.

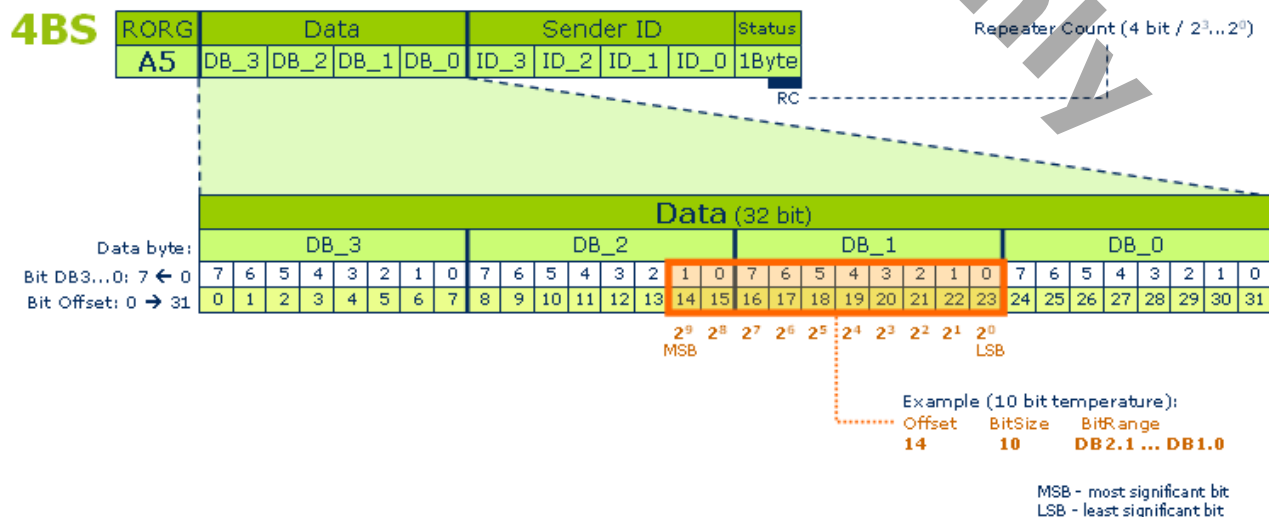

1.6.3) VLD

VLD telegrams carry a variable payload between one and 14 bytes, depending on their design. The teach-in process applies the Smart Ack procedure (see appendices 3.4 and 3.5).

The example following displays a VLD telegram with 6 bytes user data. DB_5.BIT_7 is the first transmitted bit with offset 0.

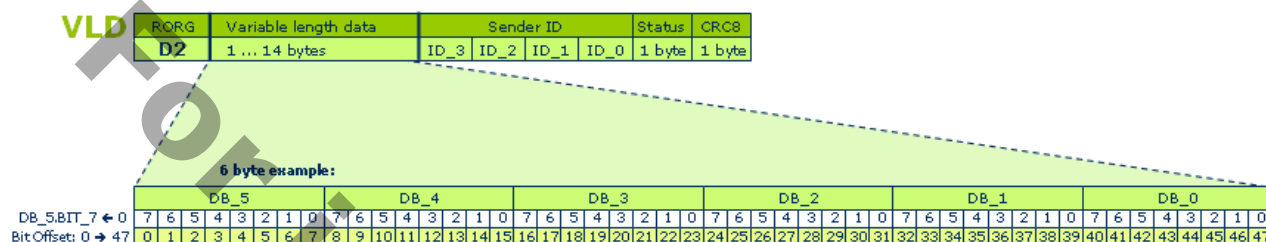

1.7) Teach-in procedures

The 'Teach-in' defines the mutual communication between wireless devices in an 868 (315) MHz radio network.

The 'Teach-in' defines to which transmitter(s) a receiver needs to listen to.

For this purpose of a determined relationship between transmitter and receiver each transmitting device has a unique Sender-ID which is part of each radio telegram. The receiving device detects from the Sender-ID whether the device is known, i.e., was already learned, or unknown.

A telegram with unknown Sender-ID is disregarded.

The 'teach-in' process is different for each telegram type (RPS, 1BS, 4BS, Smart Ack), but the following points are valid for all telegrams:

- First, the receiver must be switched into learning mode. Now, the Sender-ID of an arriving telegram is interpreted as an authorized information source and will be stored at the receiver. The further steps of 'teach-in' are defined by the device type or the telegram type. Thus, normal data telegrams or special teach-in telegrams can be used. Frequently, a learn button triggers the teach-in process.
- The telegram of the respective transmitter should be triggered at least once (by pressing the desired switch rocker or triggering a sensor).
- The bits of the payload (data bytes) can have multiple functions depending on the interpretation set by identification or status bits. Only in the 1BS and 4BS telegram the 'LRN BIT' DB_0.BIT_3 is reserved exclusively and must not be used elsewhere.

The following issues are relevant for a number of application but not mandatory for specification perspective:

- To prevent unwanted devices from being learned the input sensitivity of the receiver is often restricted, and thus an IN-ROOM operation is created. Typically, the device to be learned is placed close by the receiver.
- Dolphin-based transmitters (e.g. TCM 300 or TCM 2x with Dolphin library) can also be switched into the learn-mode via a remote management command. This remote 'teach-in' mode can only be activated within the first 30 min after a receiver power-up. To avoid inadvertent learning the transmitter telegrams have to be triggered 3 times within 2 seconds.

For further details on the 'Teach-in' processes refer to appendices 3.1 to 3.5.

1.8) Viewing XML-data

- The XML-file and all the associated files (CSS, DTD, XSL) and the 'graphics' folder must be stored in the same directory.
- The XML-file is best opened using an Internet browser, generating an HTML-view which displays the describing chapters, graphics and data tables.
- Mozilla Firefox V3.6 or upwards is recommended for optimum screen and print view.

The following example illustrates the HTML-view of the XML-data of a 4BS telegram (= payload of 32 bits).

Offset	Size	Bitrange	Data	ShortCut	Description	Valid Range	Scale	Unit
0	8	DB3.7...DB3.0	Not Used (= 0)					
8	8	DB2.7...DB2.0	Humidity	HUM	Rel. Humidity (linear)	0...250	0...100	%
16	8	DB1.7...DB1.0	Temperature	TMP	Temperature (linear)	0...250	0...40	°C
24	4	DB0.7...DB0.4	Not Used (= 0)					
28	1	DB0.3	LRN Bit	LRNB	LRN Bit	Ehum: 0: Teach-in telegram 1: Data telegram		
29	1	DB0.2	Not Used (= 0)					
30	1	DB0.1	T-Sensor	TSN	Availability of the Temperature Sensor	Ehum: 0: not available 1: available		
31	1	DB0.0	Not Used (= 0)					

Offset = start bit of data field
Size = bit number of data field
Bitrange = mapping to EEP2.0 description (specially for 4BS)
Data = content name
ShortCut = logical queries and dependencies in XML
Description of data field
Valid Range of data value
Scale of device value
Unit of scale value

ScaleMax
 ScaleMin
 RangeMax
 RangeMin

Data ranges unused are displayed in the table as white rows.

The 'Bit range' column displays the starting-point and the end-point of the respective data.

The 'Valid range', 'Scale' and 'Unit' columns are displayed separately only for measurement values. However, these 3 columns are merged into one if the data comes from an enumeration (enum).

Assuming a linear conversion between the value to be measured and the 'valid range' of data the resolution can be calculated as follows:

Conversion: Valid Range ---> Scale	
Multiplier	$= \frac{\text{Scale}_{\text{MAX}} - \text{Scale}_{\text{MIN}}}{\text{Range}_{\text{MAX}} - \text{Range}_{\text{MIN}}}$
Multiplier < 0:	Device Value = Multiplier * Data value + Scale _{MAX}
Multiplier ≥ 0:	Device Value = Multiplier * Data value + Scale _{MIN}

F6: RPS Telegram

Repeated Switch Communication

F6-02: Rocker Switch, 2 Rocker

For clarification reasons the following picture shows a PTM200 transmitter module from EnOcean GmbH which transmits RPS telegrams and is one possibility to be used in applications that require an EEP F6-02-xx. Please note that PTM200 does not support transmission of teach-in telegrams.

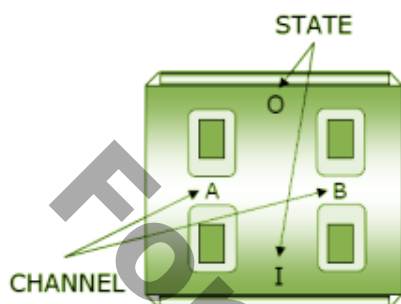

The button naming used below is referring to CHANNEL and STATE of the PTM200. Thus "Button AI" means STATE „I" on CHANNEL „A".

There are two different message types, the N-message and the U-message, which need to be identified from the Status Field of an EnOcean RPS telegram. For that reason not only the data bytes are given for each EEP but the T21 and NU bits of the Status Field are listed as well.

RORG	F6	RPS Telegram
FUNC	02	Rocker Switch, 2 Rocker
TYPE	01	Light and Blind Control - Application Style 1

This EEP definition is based on the assumption that a RPS switch module (e.g. PTM200) is installed in a 0-STATE up position! Application Style 1 is widely used in EU but may be found in other markets as well.

Statusfield:

Offset	Size	Data	Value
2	1	T21	1
3	1	NU	1

Datafield:

Offset	Size	Bitrange	Data	ShortCut	Description	Valid Range	Scale	Unit
0	3	DB0.7...DB0.5	Rocker 1st action	R1	Enum: 0: Button AI: "Switch light on" or "Dim light down" or "Move blind closed " 1: Button A0: "Switch light off" or "Dim light up" or "Move blind open " 2: Button BI: "Switch light on" or "Dim light down" or "Move blind closed" 3: Button B0: "Switch light off" or "Dim light up" or "Move blind open"		
3	1	DB0.4	Energy Bow	EB	Enum: 0: released 1: pressed		
4	3	DB0.3...DB0.1	Rocker 2nd action	R2	Enum:		

						0: Button AI: "Switch light on" or "Dim light down" or "Move blind closed "
						1: Button A0: "Switch light off" or "Dim light up" or "Move blind open "
						2: Button BI: "Switch light on" or "Dim light down" or "Move blind closed"
						3: Button B0: "Switch light off" or "Dim light up" or "Move blind open"
7	1	DB0.0	2nd Action	SA	Enum: 0: No 2nd action 1: 2nd action valid

Statusfield:

Offset	Size	Data	Value
2	1	T21	1
3	1	NU	0

Datafield:

Offset	Size	Bitrange	Data	ShortCut	Description	Valid Range	Scale	Unit
0	3	DB0.7...DB0.5	Number of buttons pressed simultaneously (other bit combinations are not valid)	R1	Enum: 0: no button 3: 3 or 4 buttons		
3	1	DB0.4	Energy Bow	EB	Enum: 0: released 1: pressed		
4	4	DB0.3...DB0.0	Not Used (= 0)					

RORG	FUNC	TYPE	F6	RPS Telegram
			F6	RPS Telegram
			02	Rocker Switch, 2 Rocker
			02	Light and Blind Control - Application Style 2

This EEP definition is based on the assumption that a RPS switch module (e.g. PTM200) is installed in an I-STATE up position! Application Style 2 is typically used in US and CAN but may be found in other markets as well.

Statusfield:

Offset	Size	Data	Value
2	1	T21	1
3	1	NU	1

Datafield:

Offset	Size	Bitrange	Data	ShortCut	Description	Valid Range	Scale	Unit
0	3	DB0.7...DB0.5	Rocker 1st action	R1	Enum: 0: Button AI: "Switch light on" or "Dim light up" or "Move blind open " 1: Button A0: "switch light off" or "Dim light down" or "Move blind closed " 2: Button BI: "Switch light on" or "Dim light up" or "Move blind open"		

						3: Button B0: "Switch light off" or "Dim light down" or "Move blind closed"
3	1	DB0.4	Energy Bow	EB	Enum: 0: released 1: pressed
4	3	DB0.3...DB0.1	Rocker 2nd action	R2	Enum: 0: Button AI: "Switch light on" or "Dim light up" or "Move blind open " 1: Button A0: "switch light off" or "Dim light down" or "Move blind closed " 2: Button BI: "Switch light on" or "Dim light up" or "Move blind open" 3: Button B0: "Switch light off" or "Dim light down" or "Move blind closed"
7	1	DB0.0	2nd Action	SA	Enum: 0: No 2nd action 1: 2nd action valid

Statusfield:

Offset	Size	Data	Value
2	1	T21	1
3	1	NU	0

Datafield:

Offset	Size	Bitrange	Data	ShortCut	Description	Valid Range	Scale	Unit
0	3	DB0.7...DB0.5	Number of buttons pressed simultaneously (other bit combinations are not valid)	R1	Enum: 0: no button 3: 3 or 4 buttons		
3	1	DB0.4	Energy Bow	EB	Enum: 0: released 1: pressed		
4	4	DB0.3...DB0.0	Not Used (= 0)					

F6-03: Rocker Switch, 4 Rocker

RORG	F6	RPS Telegram
FUNC	03	Rocker Switch, 4 Rocker
TYPE	01	Light and Blind Control - Application Style 1

This EEP definition is based on the assumption that a RPS switch module is installed in a 0-STATE up position!
Application Style 1 is widely used in EU but may be found in other markets as well.

Statusfield:

Offset	Size	Data	Value
2	1	T21	0
3	1	NU	1

Datafield:

Offset	Size	Bitrange	Data	ShortCut	Description	Valid Range	Scale	Unit
--------	------	----------	------	----------	-------------	-------------	-------	------

0	3	DB0.7...DB0.5	Rocker 1st action	R1	Enum: 0: Button AI: "Switch light on" or "Dim light down" or "Move blind closed " 1: Button A0: "Switch light off" or "Dim light up" or "Move blind open " 2: Button BI: "Switch light on" or "Dim light down" or "Move blind closed" 3: Button B0: "Switch light off" or "Dim light up" or "Move blind open" 4: Button CI: "Switch light on" or "Dim light down" or "Move blind closed " 5: Button C0: "Switch light off" or "Dim light up" or "Move blind open " 6: Button DI: "Switch light on" or "Dim light down" or "Move blind closed" 7: Button D0: "Switch light off" or "Dim light up" or "Move blind open"
3	1	DB0.4	Energy Bow	EB	Enum: 0: released 1: pressed
4	3	DB0.3...DB0.1	Rocker 2nd action	R2	Enum: 0: Button AI: "Switch light on" or "Dim light down" or "Move blind closed " 1: Button A0: "Switch light off" or "Dim light up" or "Move blind open " 2: Button BI: "Switch light on" or "Dim light down" or "Move blind closed" 3: Button B0: "Switch light off" or "Dim light up" or "Move blind open" 4: Button CI: "Switch light on" or "Dim light down" or "Move blind closed " 5: Button C0: "Switch light off" or "Dim light up" or "Move blind open " 6: Button DI: "Switch light on" or "Dim light down" or "Move blind closed" 7: Button D0: "Switch light off" or "Dim light up" or "Move blind open"
7	1	DB0.0	2nd Action	SA	Enum: 0: No 2nd action 1: 2nd action valid

Statusfield:

Offset	Size	Data	Value
2	1	T21	0
3	1	NU	0

Datafield:

Offset	Size	Bitrange	Data	ShortCut	Description	Valid Range	Scale	Unit
--------	------	----------	------	----------	-------------	-------------	-------	------

0	3	DB0.7...DB0.5	Number of buttons pressed simultaneously	R1	Enum:
						0: no Button pressed
						1: 2 buttons pressed
						2: 3 buttons pressed
						3: 4 buttons pressed
						4: 5 buttons pressed
						5: 6 buttons pressed
						6: 7 buttons pressed
7: 8 buttons pressed						
3	1	DB0.4	Energy Bow	EB	Enum:
						0: released
						1: pressed
4	4	DB0.3...DB0.0	Not Used (= 0)			

RORG	F6	RPS Telegram
FUNC	03	Rocker Switch, 4 Rocker
TYPE	02	Light and Blind Control - Application Style 2

A This EEP definition is based on the assumption that a RPS switch module is installed in a I-STATE up position!
Application Style 2 is typically used in US and CAN but may be found in other markets as well.

Statusfield:

Offset	Size	Data	Value
2	1	T21	0
3	1	NU	1

Datafield:

Offset	Size	Bitrange	Data	ShortCut	Description	Valid Range	Scale	Unit
0	3	DB0.7...DB0.5	Rocker 1st action	R1	Enum:		
						0: Button A1: "Switch light on" or "Dim light up" or "Move blind open"		
						1: Button A0: "Switch light off" or "Dim light down" or "Move blind closed"		
						2: Button B1: "Switch light on" or "Dim light up" or "Move blind open"		
						3: Button B0: "Switch light off" or "Dim light down" or "Move blind closed"		
						4: Button C1: "Switch light on" or "Dim light up" or "Move blind open"		
						5: Button C0: "Switch light off" or "Dim light down" or "Move blind closed"		
						6: Button D1: "Switch light on" or "Dim light up" or "Move blind open"		
7: Button D0: "Switch light off" or "Dim light down" or "Move blind closed"								

3	1	DB0.4	Energy Bow	EB	Enum: 0: released 1: pressed
4	3	DB0.3...DB0.1	Rocker 2nd action	R2	Enum: 0: Button AI: "Switch light on" or "Dim light up" or "Move blind open" 1: Button A0: "Switch light off" or "Dim light down" or "Move blind closed" 2: Button BI: "Switch light on" or "Dim light up" or "Move blind open" 3: Button B0: "Switch light off" or "Dim light down" or "Move blind closed" 4: Button CI: "Switch light on" or "Dim light up" or "Move blind open" 5: Button C0: "Switch light off" or "Dim light down" or "Move blind closed" 6: Button DI: "Switch light on" or "Dim light up" or "Move blind open" 7: Button D0: "Switch light off" or "Dim light down" or "Move blind closed"
7	1	DB0.0	2nd Action	SA	Enum: 0: No 2nd action 1: 2nd action valid

Statusfield:

Offset	Size	Data	Value
2	1	T21	0
3	1	NU	0

Datafield:

Offset	Size	Bitrange	Data	ShortCut	Description	Valid Range	Scale	Unit
0	3	DB0.7...DB0.5	Number of buttons pressed simultaneously	R1	Enum: 0: no button pressed 1: 2 buttons pressed 2: 3 buttons pressed 3: 4 buttons pressed 4: 5 buttons pressed 5: 6 buttons pressed 6: 7 buttons pressed 7: 8 buttons pressed		
3	1	DB0.4	Energy Bow	EB	Enum: 0: released 1: pressed		
4	4	DB0.3...DB0.0	Not Used (= 0)					

F6-04: Position Switch, Home and Office Application

RORG	F6	RPS Telegram
FUNC	04	Position Switch, Home and Office Application
TYPE	01	Key Card Activated Switch

Insertion of Key Card generates an N-Message, take-out a U-Message

Statusfield:

Offset	Size	Data	Value
2	1	T21	1
3	1	NU	1

Datafield:

Offset	Size	Bitrange	Data	ShortCut	Description	Valid Range	Scale	Unit
0	8	DB0.7...DB0.0	Key Card	KC	...	Enum: 112: inserted (0x70)		

Statusfield:

Offset	Size	Data	Value
2	1	T21	1
3	1	NU	0

Datafield:

Offset	Size	Bitrange	Data	ShortCut	Description	Valid Range	Scale	Unit
0	8	DB0.7...DB0.0	Key Card	KC	...	Enum: 0: taken out		

F6-10: Mechanical Handle

RORG	F6	RPS Telegram
FUNC	10	Mechanical Handle
TYPE	00	Window Handle

The bits marked with 'X' in DB_0 should not be checked. These bits can be '1' or '0' and should not be assumed to be a defined value, because both of them are allowed and not predictable!

Statusfield:

Offset	Size	Data	Value
2	1	T21	1
3	1	NU	0

Datafield:

Offset	Size	Bitrange	Data	ShortCut	Description	Valid Range	Scale	Unit
0	8	DB0.7...DB0.0	Window handle	WIN	Movement of the window handle	Enum: 0b11X0XXXX:		

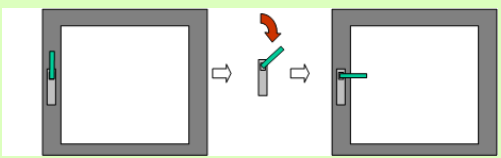

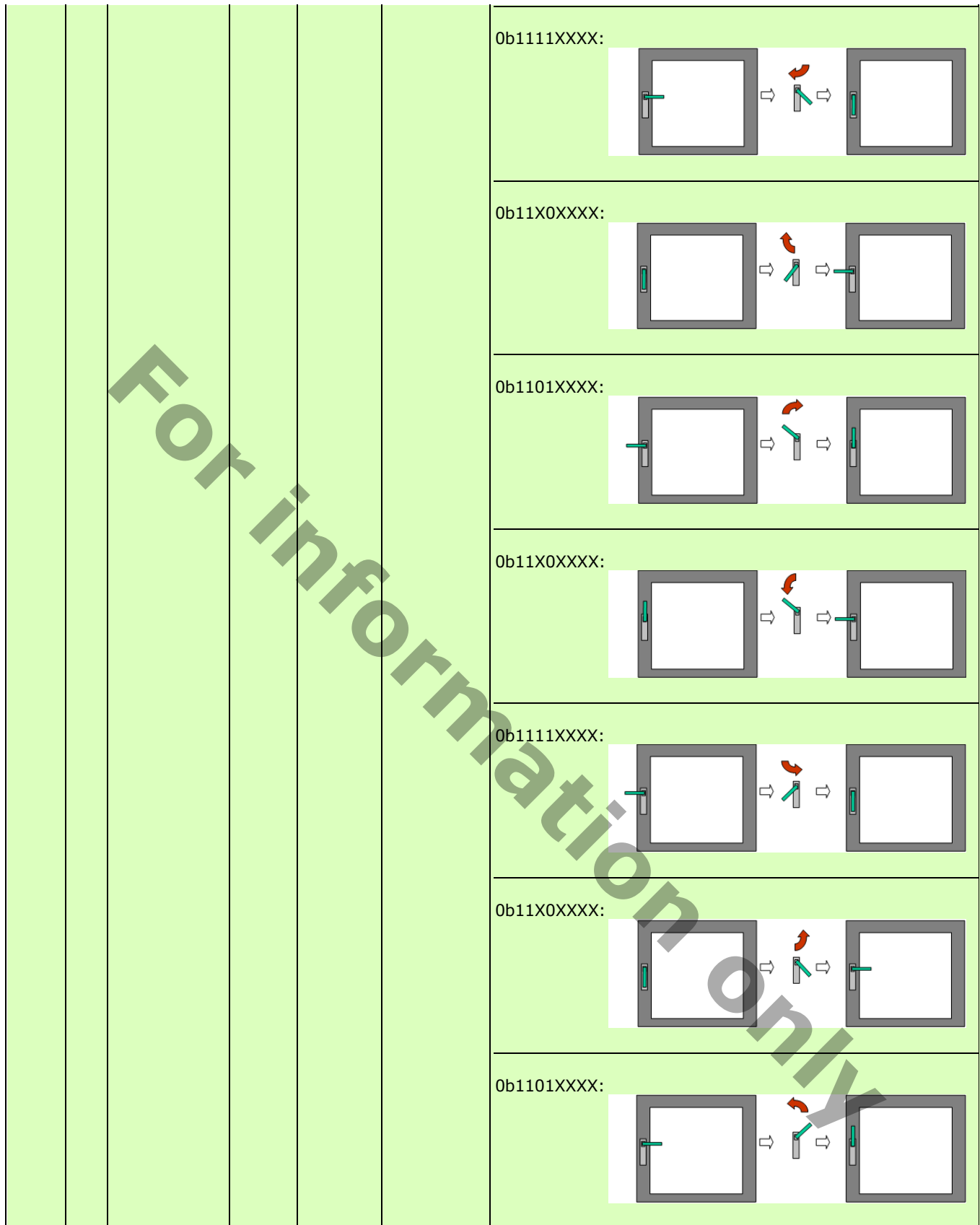

D5: 1BS Telegram

D5-00: Contacts and Switches

RORG	D5	1BS Telegram
FUNC	00	Contacts and Switches

TYPE	01	Single Input Contact
-------------	----	----------------------

Offset	Size	Bitrange	Data	ShortCut	Description	Valid Range	Scale	Unit
4	1	DB0.3	Learn Button	LRN	..	Enum: 0: pressed 1: not pressed		
7	1	DB0.0	Contact	CO		Enum: 0: open 1: closed		

A5: 4BS Telegram

A5-02: Temperature Sensors

RORG	A5	4BS Telegram
FUNC	02	Temperature Sensors
TYPE	01	Temperature Sensor Range -40°C to 0°C

Offset	Size	Bitrange	Data	ShortCut	Description	Valid Range	Scale	Unit
0	16	DB3.7...DB2.0	Not Used (= 0)					
16	8	DB1.7...DB1.0	Temperature	TMP	Temperature (linear)	255...0	-40...0	°C
24	4	DB0.7...DB0.4	Not Used (= 0)					
28	1	DB0.3	LRN Bit	LRNB	LRN Bit	Enum: 0: Teach-in telegram 1: Data telegram		
29	3	DB0.2...DB0.0	Not Used (= 0)					

RORG	A5	4BS Telegram
FUNC	02	Temperature Sensors
TYPE	02	Temperature Sensor Range -30°C to +10°C

Offset	Size	Bitrange	Data	ShortCut	Description	Valid Range	Scale	Unit
0	16	DB3.7...DB2.0	Not Used (= 0)					
16	8	DB1.7...DB1.0	Temperature	TMP	Temperature (linear)	255...0	-30...+10	°C
24	4	DB0.7...DB0.4	Not Used (= 0)					
28	1	DB0.3	LRN Bit	LRNB	LRN Bit	Enum: 0: Teach-in telegram 1: Data telegram		
29	3	DB0.2...DB0.0	Not Used (= 0)					

RORG	A5	4BS Telegram
FUNC	02	Temperature Sensors
TYPE	03	Temperature Sensor Range -20°C to +20°C

Offset	Size	Bitrange	Data	ShortCut	Description	Valid Range	Scale	Unit
0	16	DB3.7...DB2.0	Not Used (= 0)					
16	8	DB1.7...DB1.0	Temperature	TMP	Temperature (linear)	255...0	-20...+20	°C
24	4	DB0.7...DB0.4	Not Used (= 0)					
28	1	DB0.3	LRN Bit	LRNB	LRN Bit	Enum: 0: Teach-in telegram 1: Data telegram		
29	3	DB0.2...DB0.0	Not Used (= 0)					

RORG	A5	4BS Telegram
FUNC	02	Temperature Sensors
TYPE	04	Temperature Sensor Range -10°C to +30°C

Offset	Size	Bitrange	Data	ShortCut	Description	Valid Range	Scale	Unit
0	16	DB3.7...DB2.0	Not Used (= 0)					
16	8	DB1.7...DB1.0	Temperature	TMP	Temperature (linear)	255...0	-10...+30	°C
24	4	DB0.7...DB0.4	Not Used (= 0)					
28	1	DB0.3	LRN Bit	LRNB	LRN Bit	Enum: 0: Teach-in telegram 1: Data telegram		
29	3	DB0.2...DB0.0	Not Used (= 0)					

RORG	A5	4BS Telegram
FUNC	02	Temperature Sensors
TYPE	05	Temperature Sensor Range 0°C to +40°C

Offset	Size	Bitrange	Data	ShortCut	Description	Valid Range	Scale	Unit
0	16	DB3.7...DB2.0	Not Used (= 0)					
16	8	DB1.7...DB1.0	Temperature	TMP	Temperature (linear)	255...0	0...+40	°C
24	4	DB0.7...DB0.4	Not Used (= 0)					
28	1	DB0.3	LRN Bit	LRNB	LRN Bit	Enum: 0: Teach-in telegram 1: Data telegram		
29	3	DB0.2...DB0.0	Not Used (= 0)					

RORG	A5	4BS Telegram
FUNC	02	Temperature Sensors
TYPE	06	Temperature Sensor Range +10°C to +50°C

Offset	Size	Bitrange	Data	ShortCut	Description	Valid Range	Scale	Unit
0	16	DB3.7...DB2.0	Not Used (= 0)					
16	8	DB1.7...DB1.0	Temperature	TMP	Temperature (linear)	255...0	+10...+50	°C
24	4	DB0.7...DB0.4	Not Used (= 0)					

28	1	DB0.3	LRN Bit	LRNB	LRN Bit	Enum: 0: Teach-in telegram 1: Data telegram
29	3	DB0.2...DB0.0	Not Used (= 0)			

RORG	A5	4BS Telegram
FUNC	02	Temperature Sensors
TYPE	07	Temperature Sensor Range +20°C to +60°C

Offset	Size	Bitrange	Data	ShortCut	Description	Valid Range	Scale	Unit
0	16	DB3.7...DB2.0	Not Used (= 0)					
16	8	DB1.7...DB1.0	Temperature	TMP	Temperature (linear)	255...0	+20...+60	°C
24	4	DB0.7...DB0.4	Not Used (= 0)					
28	1	DB0.3	LRN Bit	LRNB	LRN Bit	Enum: 0: Teach-in telegram 1: Data telegram		
29	3	DB0.2...DB0.0	Not Used (= 0)					

RORG	A5	4BS Telegram
FUNC	02	Temperature Sensors
TYPE	08	Temperature Sensor Range +30°C to +70°C

Offset	Size	Bitrange	Data	ShortCut	Description	Valid Range	Scale	Unit
0	16	DB3.7...DB2.0	Not Used (= 0)					
16	8	DB1.7...DB1.0	Temperature	TMP	Temperature (linear)	255...0	+30...+70	°C
24	4	DB0.7...DB0.4	Not Used (= 0)					
28	1	DB0.3	LRN Bit	LRNB	LRN Bit	Enum: 0: Teach-in telegram 1: Data telegram		
29	3	DB0.2...DB0.0	Not Used (= 0)					

RORG	A5	4BS Telegram
FUNC	02	Temperature Sensors
TYPE	09	Temperature Sensor Range +40°C to +80°C

Offset	Size	Bitrange	Data	ShortCut	Description	Valid Range	Scale	Unit
0	16	DB3.7...DB2.0	Not Used (= 0)					
16	8	DB1.7...DB1.0	Temperature	TMP	Temperature (linear)	255...0	+40...+80	°C
24	4	DB0.7...DB0.4	Not Used (= 0)					
28	1	DB0.3	LRN Bit	LRNB	LRN Bit	Enum: 0: Teach-in telegram 1: Data telegram		
29	3	DB0.2...DB0.0	Not Used (= 0)					

RORG	A5	4BS Telegram
FUNC	02	Temperature Sensors
TYPE	0A	Temperature Sensor Range +50°C to +90°C

Offset	Size	Bitrange	Data	ShortCut	Description	Valid Range	Scale	Unit
0	16	DB3.7...DB2.0	Not Used (= 0)					
16	8	DB1.7...DB1.0	Temperature	TMP	Temperature (linear)	255...0	+50...+90	°C
24	4	DB0.7...DB0.4	Not Used (= 0)					
28	1	DB0.3	LRN Bit	LRNB	LRN Bit	Enum: 0: Teach-in telegram 1: Data telegram		
29	3	DB0.2...DB0.0	Not Used (= 0)					

RORG	A5	4BS Telegram
FUNC	02	Temperature Sensors
TYPE	0B	Temperature Sensor Range +60°C to +100°C

Offset	Size	Bitrange	Data	ShortCut	Description	Valid Range	Scale	Unit
0	16	DB3.7...DB2.0	Not Used (= 0)					
16	8	DB1.7...DB1.0	Temperature	TMP	Temperature (linear)	255...0	+60...+100	°C
24	4	DB0.7...DB0.4	Not Used (= 0)					
28	1	DB0.3	LRN Bit	LRNB	LRN Bit	Enum: 0: Teach-in telegram 1: Data telegram		
29	3	DB0.2...DB0.0	Not Used (= 0)					

RORG	A5	4BS Telegram
FUNC	02	Temperature Sensors
TYPE	10	Temperature Sensor Range -60°C to +20°C

Offset	Size	Bitrange	Data	ShortCut	Description	Valid Range	Scale	Unit
0	16	DB3.7...DB2.0	Not Used (= 0)					
16	8	DB1.7...DB1.0	Temperature	TMP	Temperature (linear)	255...0	-60...+20	°C
24	4	DB0.7...DB0.4	Not Used (= 0)					
28	1	DB0.3	LRN Bit	LRNB	LRN Bit	Enum: 0: Teach-in telegram 1: Data telegram		
29	3	DB0.2...DB0.0	Not Used (= 0)					

RORG	A5	4BS Telegram
FUNC	02	Temperature Sensors
TYPE	11	Temperature Sensor Range -50°C to +30°C

Offset	Size	Bitrange	Data	ShortCut	Description	Valid Range	Scale	Unit
0	16	DB3.7...DB2.0	Not Used (= 0)					
16	8	DB1.7...DB1.0	Temperature	TMP	Temperature (linear)	255...0	-50...+30	°C
24	4	DB0.7...DB0.4	Not Used (= 0)					
28	1	DB0.3	LRN Bit	LRNB	LRN Bit	Enum: 0: Teach-in telegram 1: Data telegram		
29	3	DB0.2...DB0.0	Not Used (= 0)					

RORG	A5	4BS Telegram
FUNC	02	Temperature Sensors
TYPE	12	Temperature Sensor Range -40°C to +40°C

Offset	Size	Bitrange	Data	ShortCut	Description	Valid Range	Scale	Unit
0	16	DB3.7...DB2.0	Not Used (= 0)					
16	8	DB1.7...DB1.0	Temperature	TMP	Temperature (linear)	255...0	-40...+40	°C
24	4	DB0.7...DB0.4	Not Used (= 0)					
28	1	DB0.3	LRN Bit	LRNB	LRN Bit	Enum: 0: Teach-in telegram 1: Data telegram		
29	3	DB0.2...DB0.0	Not Used (= 0)					

RORG	A5	4BS Telegram
FUNC	02	Temperature Sensors
TYPE	13	Temperature Sensor Range -30°C to +50°C

Offset	Size	Bitrange	Data	ShortCut	Description	Valid Range	Scale	Unit
0	16	DB3.7...DB2.0	Not Used (= 0)					
16	8	DB1.7...DB1.0	Temperature	TMP	Temperature (linear)	255...0	-30...+50	°C
24	4	DB0.7...DB0.4	Not Used (= 0)					
28	1	DB0.3	LRN Bit	LRNB	LRN Bit	Enum: 0: Teach-in telegram 1: Data telegram		
29	3	DB0.2...DB0.0	Not Used (= 0)					

RORG	A5	4BS Telegram
FUNC	02	Temperature Sensors
TYPE	14	Temperature Sensor Range -20°C to +60°C

Offset	Size	Bitrange	Data	ShortCut	Description	Valid Range	Scale	Unit
0	16	DB3.7...DB2.0	Not Used (= 0)					
16	8	DB1.7...DB1.0	Temperature	TMP	Temperature (linear)	255...0	-20...+60	°C
24	4	DB0.7...DB0.4	Not Used (= 0)					

28	1	DB0.3	LRN Bit	LRNB	LRN Bit	Enum: 0: Teach-in telegram 1: Data telegram
29	3	DB0.2...DB0.0	Not Used (= 0)			

RORG	A5	4BS Telegram
FUNC	02	Temperature Sensors
TYPE	15	Temperature Sensor Range -10°C to +70°C

Offset	Size	Bitrange	Data	ShortCut	Description	Valid Range	Scale	Unit
0	16	DB3.7...DB2.0	Not Used (= 0)					
16	8	DB1.7...DB1.0	Temperature	TMP	Temperature (linear)	255...0	-10...+70	°C
24	4	DB0.7...DB0.4	Not Used (= 0)					
28	1	DB0.3	LRN Bit	LRNB	LRN Bit	Enum: 0: Teach-in telegram 1: Data telegram		
29	3	DB0.2...DB0.0	Not Used (= 0)					

RORG	A5	4BS Telegram
FUNC	02	Temperature Sensors
TYPE	16	Temperature Sensor Range 0°C to +80°C

Offset	Size	Bitrange	Data	ShortCut	Description	Valid Range	Scale	Unit
0	16	DB3.7...DB2.0	Not Used (= 0)					
16	8	DB1.7...DB1.0	Temperature	TMP	Temperature (linear)	255...0	0...+80	°C
24	4	DB0.7...DB0.4	Not Used (= 0)					
28	1	DB0.3	LRN Bit	LRNB	LRN Bit	Enum: 0: Teach-in telegram 1: Data telegram		
29	3	DB0.2...DB0.0	Not Used (= 0)					

RORG	A5	4BS Telegram
FUNC	02	Temperature Sensors
TYPE	17	Temperature Sensor Range +10°C to +90°C

Offset	Size	Bitrange	Data	ShortCut	Description	Valid Range	Scale	Unit
0	16	DB3.7...DB2.0	Not Used (= 0)					
16	8	DB1.7...DB1.0	Temperature	TMP	Temperature (linear)	255...0	+10...+90	°C
24	4	DB0.7...DB0.4	Not Used (= 0)					
28	1	DB0.3	LRN Bit	LRNB	LRN Bit	Enum: 0: Teach-in telegram 1: Data telegram		
29	3	DB0.2...DB0.0	Not Used (= 0)					

RORG	A5	4BS Telegram
FUNC	02	Temperature Sensors
TYPE	18	Temperature Sensor Range +20°C to +100°C

Offset	Size	Bitrange	Data	ShortCut	Description	Valid Range	Scale	Unit
0	16	DB3.7...DB2.0	Not Used (= 0)					
16	8	DB1.7...DB1.0	Temperature	TMP	Temperature (linear)	255...0	+20...+100	°C
24	4	DB0.7...DB0.4	Not Used (= 0)					
28	1	DB0.3	LRN Bit	LRNB	LRN Bit	Enum: 0: Teach-in telegram 1: Data telegram		
29	3	DB0.2...DB0.0	Not Used (= 0)					

RORG	A5	4BS Telegram
FUNC	02	Temperature Sensors
TYPE	19	Temperature Sensor Range +30°C to +110°C

Offset	Size	Bitrange	Data	ShortCut	Description	Valid Range	Scale	Unit
0	16	DB3.7...DB2.0	Not Used (= 0)					
16	8	DB1.7...DB1.0	Temperature	TMP	Temperature (linear)	255...0	+30...+110	°C
24	4	DB0.7...DB0.4	Not Used (= 0)					
28	1	DB0.3	LRN Bit	LRNB	LRN Bit	Enum: 0: Teach-in telegram 1: Data telegram		
29	3	DB0.2...DB0.0	Not Used (= 0)					

RORG	A5	4BS Telegram
FUNC	02	Temperature Sensors
TYPE	1A	Temperature Sensor Range +40°C to +120°C

Offset	Size	Bitrange	Data	ShortCut	Description	Valid Range	Scale	Unit
0	16	DB3.7...DB2.0	Not Used (= 0)					
16	8	DB1.7...DB1.0	Temperature	TMP	Temperature (linear)	255...0	+40...+120	°C
24	4	DB0.7...DB0.4	Not Used (= 0)					
28	1	DB0.3	LRN Bit	LRNB	LRN Bit	Enum: 0: Teach-in telegram 1: Data telegram		
29	3	DB0.2...DB0.0	Not Used (= 0)					

RORG	A5	4BS Telegram
FUNC	02	Temperature Sensors
TYPE	1B	Temperature Sensor Range +50°C to +130°C

Offset	Size	Bitrange	Data	ShortCut	Description	Valid Range	Scale	Unit
0	16	DB3.7...DB2.0	Not Used (= 0)					
16	8	DB1.7...DB1.0	Temperature	TMP	Temperature (linear)	255...0	+50...+130	°C
24	4	DB0.7...DB0.4	Not Used (= 0)					
28	1	DB0.3	LRN Bit	LRNB	LRN Bit	Enum: 0: Teach-in telegram 1: Data telegram		
29	3	DB0.2...DB0.0	Not Used (= 0)					

RORG	A5	4BS Telegram
FUNC	02	Temperature Sensors
TYPE	20	10 Bit Temperature Sensor Range -10°C to +41.2°C

Offset	Size	Bitrange	Data	ShortCut	Description	Valid Range	Scale	Unit
0	14	DB3.7...DB2.2	Not Used (= 0)					
14	10	DB2.1...DB1.0	Temperature	TMP	Temperature (linear)	1023...0	-10...+41.2	°C
24	4	DB0.7...DB0.4	Not Used (= 0)					
28	1	DB0.3	LRN Bit	LRNB	LRN Bit	Enum: 0: Teach-in telegram 1: Data telegram		
29	3	DB0.2...DB0.0	Not Used (= 0)					

RORG	A5	4BS Telegram
FUNC	02	Temperature Sensors
TYPE	30	10 Bit Temperature Sensor Range -40°C to +62.3°C

Offset	Size	Bitrange	Data	ShortCut	Description	Valid Range	Scale	Unit
0	14	DB3.7...DB2.2	Not Used (= 0)					
14	10	DB2.1...DB1.0	Temperature	TMP	Temperature (linear)	1023...0	-40...+62.3	°C
24	4	DB0.7...DB0.4	Not Used (= 0)					
28	1	DB0.3	LRN Bit	LRNB	LRN Bit	Enum: 0: Teach-in telegram 1: Data telegram		
29	3	DB0.2...DB0.0	Not Used (= 0)					

A5-04: Temperature and Humidity Sensor

RORG	A5	4BS Telegram
FUNC	04	Temperature and Humidity Sensor
TYPE	01	Range 0°C to +40°C and 0% to 100%

Offset	Size	Bitrange	Data	ShortCut	Description	Valid Range	Scale	Unit
0	8	DB3.7...DB3.0	Not Used (= 0)					
8	8	DB2.7...DB2.0	Humidity	HUM	Rel. Humidity (linear)	0...250	0...100	%
16	8	DB1.7...DB1.0	Temperature	TMP	Temperature (linear)	0...250	0...+40	°C

24	4	DB0.7...DB0.4	Not Used (= 0)			
28	1	DB0.3	LRN Bit	LRNB	LRN Bit	Enum: 0: Teach-in telegram 1: Data telegram
29	1	DB0.2	Not Used (= 0)			
30	1	DB0.1	T-Sensor	TSN	Availability of the Temperature Sensor	Enum: 0: not available 1: available
31	1	DB0.0	Not Used (= 0)			

A5-06: Light Sensor

RORG	A5	4BS Telegram
FUNC	06	Light Sensor
TYPE	01	Range 300lx to 60.000lx

Offset	Size	Bitrange	Data	ShortCut	Description	Valid Range	Scale	Unit
0	8	DB3.7...DB3.0	Supply voltage	SVC	Supply voltage (linear)	0...255	0...5.1	V
8	8	DB2.7...DB2.0	Illumination	ILL2	Illumination (linear)	0...255	300...30000	lx
16	8	DB1.7...DB1.0	Illumination	ILL1	Illumination (linear)	0...255	600...60000	lx
24	4	DB0.7...DB0.4	Not Used (= 0)					
28	1	DB0.3	LRN Bit	LRNB	LRN Bit	Enum: 0: Teach-in telegram 1: Data telegram		
29	2	DB0.2...DB0.1	Not Used (= 0)					
31	1	DB0.0	Range select	RS	Range	Enum: 0: Range acc. to DB_1 (ILL1) 1: Range acc. to DB_2 (ILL2)		

RORG	A5	4BS Telegram
FUNC	06	Light Sensor
TYPE	02	Range 0lx to 1.020lx

Offset	Size	Bitrange	Data	ShortCut	Description	Valid Range	Scale	Unit
0	8	DB3.7...DB3.0	Supply voltage	SVC	Supply voltage (linear)	0...255	0...5.1	V
8	8	DB2.7...DB2.0	Illumination	ILL2	Illumination (linear)	0...255	0...510	lx
16	8	DB1.7...DB1.0	Illumination	ILL1	Illumination (linear)	0...255	0...1020	lx
24	4	DB0.7...DB0.4	Not Used (= 0)					
28	1	DB0.3	LRN Bit	LRNB	LRN Bit	Enum: 0: Teach-in telegram 1: Data telegram		
29	2	DB0.2...DB0.1	Not Used (= 0)					
31	1	DB0.0	Range select	RS	Range	Enum: 0: Range acc. to DB_1 (ILL1) 1: Range acc. to DB_2 (ILL2)		

A5-07: Occupancy Sensor

RORG	A5	4BS Telegram
FUNC	07	Occupancy Sensor
TYPE	01	Occupancy

The transmission of "PIR off" telegrams is optional.

Offset	Size	Bitrange	Data	ShortCut	Description	Valid Range	Scale	Unit
0	16	DB3.7...DB2.0	Not Used (= 0)					
16	8	DB1.7...DB1.0	PIR Status	PIRS	PIR Status	Enum: 0...127: PIR off 128...255: PIR on		
24	4	DB0.7...DB0.4	Not Used (= 0)					
28	1	DB0.3	LRN Bit	LRNB	LRN Bit	Enum: 0: Teach-in telegram 1: Data telegram		
29	2	DB0.2...DB0.1	Not Used (= 0)					

A5-08: Light, Temperature and Occupancy Sensor

RORG	A5	4BS Telegram
FUNC	08	Light, Temperature and Occupancy Sensor
TYPE	01	Range 0lx to 510lx, 0°C to +51°C and Occupancy

E.g. for ceiling suspended sensor.

Offset	Size	Bitrange	Data	ShortCut	Description	Valid Range	Scale	Unit
0	8	DB3.7...DB3.0	Supply voltage	SVC	Supply voltage (linear)	0...255	0...5.1	V
8	8	DB2.7...DB2.0	Illumination	ILL	Illumination (linear)	0...255	0...510	lx
16	8	DB1.7...DB1.0	Temperature	TMP	Temperature (linear)	0...255	0...+51	°C
24	4	DB0.7...DB0.4	Not Used (= 0)					
28	1	DB0.3	LRN Bit	LRNB	LRN Bit	Enum: 0: Teach-in telegram 1: Data telegram		
29	1	DB0.2	Not Used (= 0)					
30	1	DB0.1	PIR Status	PIRS	PIR Status	Enum: 0: PIR on 1: PIR off		
31	1	DB0.0	Occupancy	OCC	...	Enum: 0: Button pressed 1: Button released		

RORG	A5	4BS Telegram
FUNC	08	Light, Temperature and Occupancy Sensor
TYPE	02	Range 0lx to 1020lx, 0°C to +51°C and Occupancy

E.g. for wall mounted sensor.

Offset	Size	Bitrange	Data	ShortCut	Description	Valid Range	Scale	Unit
0	8	DB3.7...DB3.0	Supply voltage	SVC	Supply voltage (linear)	0...255	0...5.1	V
8	8	DB2.7...DB2.0	Illumination	ILL	Illumination (linear)	0...255	0...1020	lx
16	8	DB1.7...DB1.0	Temperature	TMP	Temperature (linear)	0...255	0...+51	°C
24	4	DB0.7...DB0.4	Not Used (= 0)					

28	1	DB0.3	LRN Bit	LRNB	LRN Bit	Enum:
						0: Teach-in telegram
						1: Data telegram
29	1	DB0.2	Not Used (= 0)			
30	1	DB0.1	PIR Status	PIRS	PIR Status	Enum:
						0: PIR on
						1: PIR off
31	1	DB0.0	Occupancy	OCC	...	Enum:
						0: Button pressed
						1: Button released

RORG	A5	4BS Telegram
FUNC	08	Light, Temperature and Occupancy Sensor
TYPE	03	Range 0lx to 1530lx, -30°C to +50°C and Occupancy

E.g. for outdoor sensor.

Offset	Size	Bitrange	Data	ShortCut	Description	Valid Range	Scale	Unit
0	8	DB3.7...DB3.0	Supply voltage	SVC	Supply voltage (linear)	0...255	0...5.1	V
8	8	DB2.7...DB2.0	Illumination	ILL	Illumination (linear)	0...255	0...1530	lx
16	8	DB1.7...DB1.0	Temperature	TMP	Temperature (linear)	0...255	-30...+50	°C
24	4	DB0.7...DB0.4	Not Used (= 0)					
28	1	DB0.3	LRN Bit	LRNB	LRN Bit	Enum:		
						0: Teach-in telegram		
						1: Data telegram		
29	1	DB0.2	Not Used (= 0)					
30	1	DB0.1	PIR Status	PIRS	PIR Status	Enum:		
						0: PIR on		
						1: PIR off		
31	1	DB0.0	Occupancy	OCC	..	Enum:		
						0: Button pressed		
						1: Button released		

A5-09: Gas Sensor

RORG	A5	4BS Telegram
FUNC	09	Gas Sensor
TYPE	01	CO Sensor (tbd!)

Offset	Size	Bitrange	Data	ShortCut	Description	Valid Range	Scale	Unit
0	8	DB3.7...DB3.0	Concentration	Conc	Concentration	0...255	0...255	ppm
8	8	DB2.7...DB2.0	Concentration	Conc	Concentration	0...255	0...255	ppm
16	8	DB1.7...DB1.0	Temperature	TMP	Temperature (linear)	0...255	0...+255	°C
24	4	DB0.7...DB0.4	Not Used (= 0)					
28	1	DB0.3	LRN Bit	LRNB	LRN Bit	Enum:		
						0: Teach-in telegram		
						1: Data telegram		
29	1	DB0.2	Not Used (= 0)					
30	1	DB0.1	T-Sensor	TSN	..	Enum:		
						0: Temperature Sensor not available		
						1: Temperature Sensor available		
31	1	DB0.0	Not Used (= 0)					

RORG	A5	4BS Telegram
FUNC	09	Gas Sensor
TYPE	04	CO2 Sensor

Offset	Size	Bitrange	Data	ShortCut	Description	Valid Range	Scale	Unit
0	8	DB3.7...DB3.0	Humidity	HUM	Rel. Humidity (linear), 0.5 % = 1 bit	0...200	0...100	%
8	8	DB2.7...DB2.0	Concentration	Conc	Concentration (linear), 10 ppm = 1 bit	0...255	0...2550	ppm
16	8	DB1.7...DB1.0	Temperature	TMP	Temperature (linear), 0.2 °C = 1 bit	0...255	0...+51.0	°C
24	4	DB0.7...DB0.4	Not Used (= 0)					
28	1	DB0.3	LRN Bit	LRNB	LRN Bit	Enum: 0: Teach-in telegram 1: Data telegram		
29	1	DB0.2	H-Sensor	HSN	..	Enum: 0: Humidity Sensor not available 1: Humidity Sensor available		
30	1	DB0.1	T-Sensor	TSN	..	Enum: 0: Temperature Sensor not available 1: Temperature Sensor available		
31	1	DB0.0	Not Used (= 0)					

A5-10: Room Operating Panel

RORG	A5	4BS Telegram
FUNC	10	Room Operating Panel
TYPE	01	Temperature Sensor, Set Point, Fan Speed and Occupancy Control

Offset	Size	Bitrange	Data	ShortCut	Description	Valid Range	Scale	Unit
0	8	DB3.7...DB3.0	Turn-switch for fan speed	FAN	Turn-switch for fan speed	Enum: 210...255: Stage Auto 190...209: Stage 0 165...189: Stage 1 145...164: Stage 2 0...144: Stage 3		
8	8	DB2.7...DB2.0	Set point	SP	Set point (linear) Min.- ... Max+	0...255	0...255	N/A
16	8	DB1.7...DB1.0	Temperature	TMP	Temperature (linear)	255...0	0...+40	°C
24	4	DB0.7...DB0.4	Not Used (= 0)					
28	1	DB0.3	LRN Bit	LRNB	LRN Bit	Enum: 0: Teach-in telegram 1: Data telegram		
29	2	DB0.2...DB0.1	Not Used (= 0)					

31	1	DB0.0	Occupancy	OCC	Occupancy button	Enum:
						1: Button released
						0: Button pressed

RORG	A5	4BS Telegram
FUNC	10	Room Operating Panel
TYPE	02	Temperature Sensor, Set Point, Fan Speed and Day/Night Control

Offset	Size	Bitrange	Data	ShortCut	Description	Valid Range	Scale	Unit
0	8	DB3.7...DB3.0	Turn-switch for fan speed	FAN	Turn-switch for fan speed	Enum: 210...255: Stage Auto 190...209: Stage 0 165...189: Stage 1 145...164: Stage 2 0...144: Stage 3		
8	8	DB2.7...DB2.0	Set point	SP	Set point (linear) Min.- ... Max+	0...255	0...255	N/A
16	8	DB1.7...DB1.0	Temperature	TMP	Temperature (linear)	255...0	0...+40	°C
24	4	DB0.7...DB0.4	Not Used (= 0)					
28	1	DB0.3	LRN Bit	LRNB	LRN Bit	Enum: 0: Teach-in telegram 1: Data telegram		
29	2	DB0.2...DB0.1	Not Used (= 0)					
31	1	DB0.0	Slide switch 0/I	SLSW	Slide switch or Slide switch Day/Night	Enum: 0: Position I / Night / Off 1: Position O / Day / On		

RORG	A5	4BS Telegram
FUNC	10	Room Operating Panel
TYPE	03	Temperature Sensor, Set Point Control

Offset	Size	Bitrange	Data	ShortCut	Description	Valid Range	Scale	Unit
0	8	DB3.7...DB3.0	Not Used (= 0)					
8	8	DB2.7...DB2.0	Set point	SP	Set point (linear) Min.- ... Max+	0...255	0...255	N/A
16	8	DB1.7...DB1.0	Temperature	TMP	Temperature (linear)	255...0	0...+40	°C
24	4	DB0.7...DB0.4	Not Used (= 0)					
28	1	DB0.3	LRN Bit	LRNB	LRN Bit	Enum: 0: Teach-in telegram 1: Data telegram		
29	3	DB0.2...DB0.0	Not Used (= 0)					

RORG	A5	4BS Telegram
FUNC	10	Room Operating Panel
TYPE	04	Temperature Sensor, Set Point and Fan Speed Control

Offset	Size	Bitrange	Data	ShortCut	Description	Valid Range	Scale	Unit
0	8	DB3.7...DB3.0	Turn-switch for fan speed	FAN	..	Enum: 210...255: Stage Auto 190...209: Stage 0 165...189: Stage 1 145...164: Stage 2 0...144: Stage 3		
8	8	DB2.7...DB2.0	Set point	SP	Set point (linear) Min.- ... Max+	0...255	0...255	N/A
16	8	DB1.7...DB1.0	Temperature	TMP	Temperature (linear)	255...0	0...+40	°C
24	4	DB0.7...DB0.4	Not Used (= 0)					
28	1	DB0.3	LRN Bit	LRNB	LRN Bit	Enum: 0: Teach-in telegram 1: Data telegram		
29	3	DB0.2...DB0.0	Not Used (= 0)					

RORG	A5	4BS Telegram
FUNC	10	Room Operating Panel
TYPE	05	Temperature Sensor, Set Point and Occupancy Control

Offset	Size	Bitrange	Data	ShortCut	Description	Valid Range	Scale	Unit
0	8	DB3.7...DB3.0	Not Used (= 0)					
8	8	DB2.7...DB2.0	Set point	SP	Set point (linear) Min.- ... Max+	0...255	0...255	N/A
16	8	DB1.7...DB1.0	Temperature	TMP	Temperature (linear)	255...0	0...+40	°C
24	4	DB0.7...DB0.4	Not Used (= 0)					
28	1	DB0.3	LRN Bit	LRNB	LRN Bit	Enum: 0: Teach-in telegram 1: Data telegram		
29	2	DB0.2...DB0.1	Not Used (= 0)					
31	1	DB0.0	Occupancy	OCC	Occupancy button	Enum: 1: Button released 0: Button pressed		

RORG	A5	4BS Telegram
FUNC	10	Room Operating Panel
TYPE	06	Temperature Sensor, Set Point and Day/Night Control

Offset	Size	Bitrange	Data	ShortCut	Description	Valid Range	Scale	Unit
0	8	DB3.7...DB3.0	Not Used (= 0)					
8	8	DB2.7...DB2.0	Set point	SP	Set point (linear) Min.- ... Max+	0...255	0...255	N/A
16	8	DB1.7...DB1.0	Temperature	TMP	Temperature (linear)	255...0	0...+40	°C
24	4	DB0.7...DB0.4	Not Used (= 0)					
28	1	DB0.3	LRN Bit	LRNB	LRN Bit	Enum: 0: Teach-in telegram 1: Data telegram		
29	2	DB0.2...DB0.1	Not Used (= 0)					

31	1	DB0.0	Slide switch 0/I	SLSW	Slide switch or Slide switch Day/Night	Enum:
						0: Position I / Night / Off
						1: Position O / Day / On

RORG	A5	4BS Telegram
FUNC	10	Room Operating Panel
TYPE	07	Temperature Sensor, Fan Speed Control

Offset	Size	Bitrange	Data	ShortCut	Description	Valid Range	Scale	Unit	
0	8	DB3.7...DB3.0	Turn-switch for fan speed	FAN	..	Enum:			
						210...255: Stage Auto			
						190...209: Stage 0			
						165...189: Stage 1			
						145...164: Stage 2			
		0...144: Stage 3							
8	8	DB2.7...DB2.0	Not Used (= 0)						
16	8	DB1.7...DB1.0	Temperature	TMP	Temperature (linear)	255...0	0...+40	°C	
24	4	DB0.7...DB0.4	Not Used (= 0)						
28	1	DB0.3	LRN Bit	LRNB	LRN Bit	Enum:			
						0: Teach-in telegram			
						1: Data telegram			
29	3	DB0.2...DB0.0	Not Used (= 0)						

RORG	A5	4BS Telegram
FUNC	10	Room Operating Panel
TYPE	08	Temperature Sensor, Fan Speed and Occupancy Control

Offset	Size	Bitrange	Data	ShortCut	Description	Valid Range	Scale	Unit	
0	8	DB3.7...DB3.0	Turn-switch for fan speed	FAN	..	Enum:			
						210...255: Stage Auto			
						190...209: Stage 0			
						165...189: Stage 1			
						145...164: Stage 2			
		0...144: Stage 3							
8	8	DB2.7...DB2.0	Not Used (= 0)						
16	8	DB1.7...DB1.0	Temperature	TMP	Temperature (linear)	255...0	0...+40	°C	
24	4	DB0.7...DB0.4	Not Used (= 0)						
28	1	DB0.3	LRN Bit	LRNB	LRN Bit	Enum:			
						0: Teach-in telegram			
						1: Data telegram			
29	2	DB0.2...DB0.1	Not Used (= 0)						
31	1	DB0.0	Occupancy	OCC	Occupancy button	Enum:			
						1: Button released			
						0: Button pressed			

RORG	A5	4BS Telegram
-------------	----	---------------------

FUNC	10	Room Operating Panel
TYPE	09	Temperature Sensor, Fan Speed and Day/Night Control

Offset	Size	Bitrange	Data	ShortCut	Description	Valid Range	Scale	Unit
0	8	DB3.7...DB3.0	Turn-switch for fan speed	FAN	..	Enum: 210...255: Stage Auto 190...209: Stage 0 165...189: Stage 1 145...164: Stage 2 0...144: Stage 3		
8	8	DB2.7...DB2.0	Not Used (= 0)					
16	8	DB1.7...DB1.0	Temperature	TMP	Temperature (linear)	255...0	0...+40	°C
24	4	DB0.7...DB0.4	Not Used (= 0)					
28	1	DB0.3	LRN Bit	LRNB	LRN Bit	Enum: 0: Teach-in telegram 1: Data telegram		
29	2	DB0.2...DB0.1	Not Used (= 0)					
31	1	DB0.0	Slide switch 0/I	SLSW	Slide switch or Slide switch Day/Night	Enum: 0: Position I / Night / Off 1: Position O / Day / On		

RORG	A5	4BS Telegram
FUNC	10	Room Operating Panel
TYPE	0A	Temperature Sensor, Set Point Adjust and Single Input Contact

Offset	Size	Bitrange	Data	ShortCut	Description	Valid Range	Scale	Unit
0	8	DB3.7...DB3.0	Not Used (= 0)					
8	8	DB2.7...DB2.0	Set point	SP	Set point (linear) Min.- ... Max+	0...255	0...255	N/A
16	8	DB1.7...DB1.0	Temperature	TMP	Temperature (linear)	255...0	0...+40	°C
24	4	DB0.7...DB0.4	Not Used (= 0)					
28	1	DB0.3	LRN Bit	LRNB	LRN Bit	Enum: 0: Teach-in telegram 1: Data telegram		
29	2	DB0.2...DB0.1	Not Used (= 0)					
31	1	DB0.0	Contact State	CTST	Contact state	Enum: 0: closed 1: open		

RORG	A5	4BS Telegram
FUNC	10	Room Operating Panel
TYPE	0B	Temperature Sensor and Single Input Contact

Offset	Size	Bitrange	Data	ShortCut	Description	Valid Range	Scale	Unit
0	16	DB3.7...DB2.0	Not Used (= 0)					
16	8	DB1.7...DB1.0	Temperature	TMP	Temperature (linear)	255...0	0...+40	°C
24	4	DB0.7...DB0.4	Not Used (= 0)					

28	1	DB0.3	LRN Bit	LRNB	LRN Bit	Enum:
						0: Teach-in telegram
						1: Data telegram
29	2	DB0.2...DB0.1	Not Used (= 0)			
31	1	DB0.0	Contact State	CTST	Contact state	Enum:
						0: closed
						1: open

RORG	A5	4BS Telegram
FUNC	10	Room Operating Panel
TYPE	0C	Temperature Sensor and Occupancy Control

Offset	Size	Bitrange	Data	ShortCut	Description	Valid Range	Scale	Unit
0	16	DB3.7...DB2.0	Not Used (= 0)					
16	8	DB1.7...DB1.0	Temperature	TMP	Temperature (linear)	255...0	0...+40	°C
24	4	DB0.7...DB0.4	Not Used (= 0)					
28	1	DB0.3	LRN Bit	LRNB	LRN Bit	Enum:		
						0: Teach-in telegram		
						1: Data telegram		
29	2	DB0.2...DB0.1	Not Used (= 0)					
31	1	DB0.0	Occupancy	OCC	Occupancy button	Enum:		
						1: Button released		
						0: Button pressed		

RORG	A5	4BS Telegram
FUNC	10	Room Operating Panel
TYPE	0D	Temperature Sensor and Day/Night Control

Offset	Size	Bitrange	Data	ShortCut	Description	Valid Range	Scale	Unit
0	16	DB3.7...DB2.0	Not Used (= 0)					
16	8	DB1.7...DB1.0	Temperature	TMP	Temperature (linear)	255...0	0...+40	°C
24	4	DB0.7...DB0.4	Not Used (= 0)					
28	1	DB0.3	LRN Bit	LRNB	LRN Bit	Enum:		
						0: Teach-in telegram		
						1: Data telegram		
29	2	DB0.2...DB0.1	Not Used (= 0)					
31	1	DB0.0	Slide switch	SLSW	Slide switch 0/I or Slide switch Day/Night	Enum:		
						0: Position I / Night / Off		
						1: Position O / Day / On		

RORG	A5	4BS Telegram
FUNC	10	Room Operating Panel
TYPE	10	Temperature and Humidity Sensor, Set Point and Occupancy Control

Offset	Size	Bitrange	Data	ShortCut	Description	Valid Range	Scale	Unit
0	8	DB3.7...DB3.0	Set point	SP	Set point (linear) Min.- ... Max+	0...255	0...255	N/A
8	8	DB2.7...DB2.0	Humidity	HUM	Rel. Humidity (linear)	0...250	0...100	%
16	8	DB1.7...DB1.0	Temperature	TMP	Temperature (linear)	0...250	0...+40	°C
24	4	DB0.7...DB0.4	Not Used (= 0)					
28	1	DB0.3	LRN Bit	LRNB	LRN Bit	Enum: 0: Teach-in telegram 1: Data telegram		
29	2	DB0.2...DB0.1	Not Used (= 0)					
31	1	DB0.0	Occupancy	OCC	Occupancy button	Enum: 1: Button released 0: Button pressed		

RORG	A5	4BS Telegram
FUNC	10	Room Operating Panel
TYPE	11	Temperature and Humidity Sensor, Set Point and Day/Night Control

Offset	Size	Bitrange	Data	ShortCut	Description	Valid Range	Scale	Unit
0	8	DB3.7...DB3.0	Set point	SP	Set point (linear) Min.- ... Max+	0...255	0...255	N/A
8	8	DB2.7...DB2.0	Humidity	HUM	Rel. Humidity (linear)	0...250	0...100	%
16	8	DB1.7...DB1.0	Temperature	TMP	Temperature (linear)	0...250	0...+40	°C
24	4	DB0.7...DB0.4	Not Used (= 0)					
28	1	DB0.3	LRN Bit	LRNB	LRN Bit	Enum: 0: Teach-in telegram 1: Data telegram		
29	2	DB0.2...DB0.1	Not Used (= 0)					
31	1	DB0.0	Slide switch	SLSW	Slide switch 0/1 or Slide switch Day/Night	Enum: 0: Position I / Night / Off 1: Position O / Day / On		

RORG	A5	4BS Telegram
FUNC	10	Room Operating Panel
TYPE	12	Temperature and Humidity Sensor and Set Point

Offset	Size	Bitrange	Data	ShortCut	Description	Valid Range	Scale	Unit
0	8	DB3.7...DB3.0	Set point	SP	Set point (linear) Min.- ... Max+	0...255	0...255	N/A
8	8	DB2.7...DB2.0	Humidity	HUM	Rel. Humidity (linear)	0...250	0...100	%
16	8	DB1.7...DB1.0	Temperature	TMP	Temperature (linear)	0...250	0...+40	°C
24	4	DB0.7...DB0.4	Not Used (= 0)					
28	1	DB0.3	LRN Bit	LRNB	LRN Bit	Enum: 0: Teach-in telegram 1: Data telegram		
29	3	DB0.2...DB0.0	Not Used (= 0)					

RORG	A5	4BS Telegram
FUNC	10	Room Operating Panel

TYPE	13	Temperature and Humidity Sensor, Occupancy Control
-------------	----	--

Offset	Size	Bitrange	Data	ShortCut	Description	Valid Range	Scale	Unit
0	8	DB3.7...DB3.0	Not Used (= 0)					
8	8	DB2.7...DB2.0	Humidity	HUM	Rel. Humidity (linear)	0...250	0...100	%
16	8	DB1.7...DB1.0	Temperature	TMP	Temperature (linear)	0...250	0...+40	°C
24	4	DB0.7...DB0.4	Not Used (= 0)					
28	1	DB0.3	LRN Bit	LRNB	LRN Bit	Enum: 0: Teach-in telegram 1: Data telegram		
29	2	DB0.2...DB0.1	Not Used (= 0)					
31	1	DB0.0	Occupancy	OCC	Occupancy button	Enum: 1: Button released 0: Button pressed		

RORG	A5	4BS Telegram
FUNC	10	Room Operating Panel
TYPE	14	Temperature and Humidity Sensor, Day/Night Control

Offset	Size	Bitrange	Data	ShortCut	Description	Valid Range	Scale	Unit
0	8	DB3.7...DB3.0	Not Used (= 0)					
8	8	DB2.7...DB2.0	Humidity	HUM	Rel. Humidity (linear)	0...250	0...100	%
16	8	DB1.7...DB1.0	Temperature	TMP	Temperature (linear)	0...250	0...+40	°C
24	4	DB0.7...DB0.4	Not Used (= 0)					
28	1	DB0.3	LRN Bit	LRNB	LRN Bit	Enum: 0: Teach-in telegram 1: Data telegram		
29	2	DB0.2...DB0.1	Not Used (= 0)					
31	1	DB0.0	Slide switch	SLSW	Slide switch 0/I or Slide switch Day/Night	Enum: 0: Position I / Night / Off 1: Position O / Day / On		

RORG	A5	4BS Telegram
FUNC	10	Room Operating Panel
TYPE	15	10 Bit Temperature Sensor, 6 bit Set Point Control

Offset	Size	Bitrange	Data	ShortCut	Description	Valid Range	Scale	Unit
0	8	DB3.7...DB3.0	Not Used (= 0)					
8	6	DB2.7...DB2.2	Set point	SP	Set point (6 bit, linear) Min.- ... Max+	0...63	0...63	N/A
14	10	DB2.1...DB1.0	Temperature	TMP	Temperature 10 bit (linear)	0...1023	-10...+41.2	°C
24	4	DB0.7...DB0.4	Not Used (= 0)					
28	1	DB0.3	LRN Bit	LRNB	LRN Bit	Enum: 0: Teach-in telegram 1: Data telegram		
29	3	DB0.2...DB0.0	Not Used (= 0)					

RORG	A5	4BS Telegram
FUNC	10	Room Operating Panel
TYPE	16	10 Bit Temperature Sensor, 6 bit Set Point Control;Occupancy Control

Offset	Size	Bitrange	Data	ShortCut	Description	Valid Range	Scale	Unit
0	8	DB3.7...DB3.0	Not Used (= 0)					
8	6	DB2.7...DB2.2	Set point	SP	Set point (linear) Min.- ... Max+	0...63	0...63	N/A
14	10	DB2.1...DB1.0	Temperature	TMP	Temperature 10 bit (linear)	0...1023	-10...+41.2	°C
24	4	DB0.7...DB0.4	Not Used (= 0)					
28	1	DB0.3	LRN Bit	LRNB	LRN Bit	Enum: 0: Teach-in telegram 1: Data telegram		
29	2	DB0.2...DB0.1	Not Used (= 0)					
31	1	DB0.0	Occupancy	OCC	Occupancy button	Enum: 1: Button released 0: Button pressed		

RORG	A5	4BS Telegram
FUNC	10	Room Operating Panel
TYPE	17	10 Bit Temperature Sensor, Occupancy Control

Offset	Size	Bitrange	Data	ShortCut	Description	Valid Range	Scale	Unit
0	14	DB3.7...DB2.2	Not Used (= 0)					
14	10	DB2.1...DB1.0	Temperature	TMP	Temperature 10 bit (linear)	0...1023	-10...+41.2	°C
24	4	DB0.7...DB0.4	Not Used (= 0)					
28	1	DB0.3	LRN Bit	LRNB	LRN Bit	Enum: 0: Teach-in telegram 1: Data telegram		
29	2	DB0.2...DB0.1	Not Used (= 0)					
31	1	DB0.0	Occupancy	OCC	Occupancy button	Enum: 1: Button released 0: Button pressed		

RORG	A5	4BS Telegram
FUNC	10	Room Operating Panel
TYPE	18	Illumination, Temperature Set Point, Temperature Sensor, Fan Speed and Occupancy Control

Not approved

Offset	Size	Bitrange	Data	ShortCut	Description	Valid Range	Scale	Unit
0	8	DB3.7...DB3.0	Illumination	ILL	Illumination (linear), 251: Over range, 252-255: reserved	0...250	0...1000	lx

8	8	DB2.7...DB2.0	Temp Setpoint	TMPSP	Temperature Set point (linear)	250...0	0...+40	°C
16	8	DB1.7...DB1.0	Temperature	TMP	Temperature (linear)	250...0	0...+40	°C
24	1	DB0.7	Not Used (= 0)					
25	3	DB0.6...DB0.4	Fan Speed	FAN	Fan Speed	Enum: 0: Auto 1: Speed 0 2: Speed 1 3: Speed 2 4: Speed 3 5: Speed 4 6: Speed 5 7: Off		
28	1	DB0.3	LRN Bit	LRNB	LRN Bit	Enum: 0: Teach-in telegram 1: Data telegram		
29	1	DB0.2	Not Used (= 0)					
30	1	DB0.1	Occupancy enable/disable	OED	...	Enum: 0: Occupancy enabled 1: Occupancy disabled		
31	1	DB0.0	Occupancy button	OB	...	Enum: 0: Button pressed 1: Button released		

RORG FUNC TYPE	A5	4BS Telegram
	10	Room Operating Panel
	19	Humidity, Temperature Set Point, Temperature Sensor, Fan Speed and Occupancy Control

Not approved

Offset	Size	Bitrange	Data	ShortCut	Description	Valid Range	Scale	Unit
0	8	DB3.7...DB3.0	Humidity	HUM	Rel. Humidity (linear)	0...250	0...100	%
8	8	DB2.7...DB2.0	Temp Setpoint	TMP Sp	Temperature Set point (linear)	250...0	0...+40	°C
16	8	DB1.7...DB1.0	Temperature	TMP	Temperature (linear)	250...0	0...+40	°C
24	1	DB0.7	Not Used (= 0)					
25	3	DB0.6...DB0.4	Fan speed	FAN	Fan Speed	Enum: 0: Auto 1: Speed 0 2: Speed 1 3: Speed 2 4: Speed 3 5: Speed 4 6: Speed 5 7: Off		
28	1	DB0.3	LRN Bit	LRNB	LRN Bit	Enum: 0: Teach-in telegram 1: Data telegram		
29	1	DB0.2	Not Used (= 0)					

30	1	DB0.1	Occupancy button	OB		Enum: 0: Button pressed 1: Button released
31	1	DB0.0	Occupancy enable/disable	OED		Enum: 0: Occupancy enabled 1: Occupancy disabled

RORG	A5	4BS Telegram
FUNC	10	Room Operating Panel
TYPE	1A	Supply voltage monitor, Temperature Set Point, Temperature Sensor, Fan Speed and Occupancy Control

Not approved

Offset	Size	Bitrange	Data	ShortCut	Description	Valid Range	Scale	Unit
0	8	DB3.7...DB3.0	Supply Voltage	SV	0 ... 5.0 V linear (super cap); 251-255 reserved for error code	0...250	0...5	V
8	8	DB2.7...DB2.0	Temp Setpoint	TMP Sp	Temperature Set Point (linear)	250...0	0...+40	°C
16	8	DB1.7...DB1.0	Temperature	TMP	Temperature (linear)	250...0	0...+40	°C
24	1	DB0.7	Not Used (= 0)					
25	3	DB0.6...DB0.4	Fan speed	FAN	Fan Speed	Enum: 0: Auto 1: Speed 0 2: Speed 1 3: Speed 2 4: Speed 3 5: Speed 4 6: Speed 5 7: Off		
28	1	DB0.3	LRN Bit	LRNB	LRN Bit	Enum: 0: Teach-in telegram 1: Data telegram		
29	1	DB0.2	Not Used (= 0)					
30	1	DB0.1	Occupancy enable/disable	OED		Enum: 0: Occupancy enabled 1: Occupancy disabled		
31	1	DB0.0	Occupancy button	OB		Enum: 0: Button pressed 1: Button released		

RORG	A5	4BS Telegram
FUNC	10	Room Operating Panel
TYPE	1B	Supply Voltage Monitor, Illumination, Temperature Sensor, Fan Speed and Occupancy Control

Not approved

Offset	Size	Bitrange	Data	ShortCut	Description	Valid Range	Scale	Unit
0	8	DB3.7...DB3.0	Supply Voltage	SV	(super cap) 251 – 255 reserved for error code	0...250	0...5	V
8	8	DB2.7...DB2.0	Illumination	ILL	Illumination (linear), 251: Over range, 252-255: reserved	0...250	0...1000	lx
16	8	DB1.7...DB1.0	Temperature	TMP	Temperature (linear)	250...0	0...+40	°C
24	1	DB0.7	Not Used (= 0)					
25	3	DB0.6...DB0.4	Fan speed	FAN	Fan Speed	Enum: 0: Auto 1: Speed 0 2: Speed 1 3: Speed 2 4: Speed 3 5: Speed 4 6: Speed 5 7: Off		
28	1	DB0.3	LRN Bit	LRNB	LRN Bit	Enum: 0: Teach-in telegram 1: Data telegram		
29	1	DB0.2	Not Used (= 0)					
30	1	DB0.1	Occupancy enable/disable	OED		Enum: 0: Occupancy enabled 1: Occupancy disabled		
31	1	DB0.0	Occupancy button	OB		Enum: 0: Button pressed 1: Button released		

RORG FUNC TYPE	A5	4BS Telegram
	10	Room Operating Panel
	1C	Illumination, Illumination Set Point, Temperature Sensor, Fan Speed and Occupancy Control

Not approved

Offset	Size	Bitrange	Data	ShortCut	Description	Valid Range	Scale	Unit
0	8	DB3.7...DB3.0	Illumination	ILL	Illumination (linear), 251: Over range, 252-255: reserved	0...250	0...1000	lx
8	8	DB2.7...DB2.0	Illumination Set Point	ILLSP		0...250	0...1000	lx
16	8	DB1.7...DB1.0	Temperature	TMP	Temperature (linear)	250...0	0...+40	°C
24	1	DB0.7	Not Used (= 0)					
25	3	DB0.6...DB0.4	Fan speed	FAN		Enum: 0: Auto 1: Speed 0 2: Speed 1 3: Speed 2 4: Speed 3		

						5: Speed 4	
						6: Speed 5	
						7: Off	
28	1	DB0.3	LRN Bit	LRNB	LRN Bit	Enum: 0: Teach-in telegram 1: Data telegram	
29	1	DB0.2	Not Used (= 0)				
30	1	DB0.1	Occupancy enable/disable	OED		Enum: 0: Occupancy enabled 1: Occupancy disabled	
31	1	DB0.0	Occupancy button	OB		Enum: 0: Button pressed 1: Button released	

RORG	A5	4BS Telegram
FUNC	10	Room Operating Panel
TYPE	1D	Humidity, Humidity Set Point, Temperature Sensor, Fan Speed and Occupancy Control

Not approved

Offset	Size	Bitrange	Data	ShortCut	Description	Valid Range	Scale	Unit
0	8	DB3.7...DB3.0	Humidity	HUM	Rel. Humidity (linear)	0...250	0...100	%
8	8	DB2.7...DB2.0	Humidity Set Point	HUMSP	Humidity Set Point (linear)	0...250	0...100	%
16	8	DB1.7...DB1.0	Temperature	TMP	Temperature (linear)	250...0	0...+40	°C
24	1	DB0.7	Not Used (= 0)					
25	3	DB0.6...DB0.4	Fan speed	FAN	Fan Speed	Enum: 0: Auto 1: Speed 0 2: Speed 1 3: Speed 2 4: Speed 3 5: Speed 4 6: Speed 5 7: Off		
28	1	DB0.3	LRN Bit	LRNB	LRN Bit	Enum: 0: Teach-in telegram 1: Data telegram		
29	1	DB0.2	Not Used (= 0)					
30	1	DB0.1	Occupancy enable/disable	OED		Enum: 0: Occupancy enabled 1: Occupancy disabled		
31	1	DB0.0	Occupancy button	OB		Enum: 0: Button pressed 1: Button released		

RORG	A5	4BS Telegram
-------------	----	---------------------

FUNC	10	Room Operating Panel
	TYPE	1E

Not approved

Offset	Size	Bitrange	Data	ShortCut	Description	Valid Range	Scale	Unit
0	8	DB3.7...DB3.0	Supply Voltage	SV	0...5.0 V linear (super cap); 251-255 reserved for error code	0...250	0...5.0	V
8	8	DB2.7...DB2.0	Illumination	ILL	Illumination (linear), 251: Over range, 252-255: reserved	0...250	0...1000	lx
16	8	DB1.7...DB1.0	Temperature	TMP	Temperature (linear)	250...0	0...+40	°C
24	1	DB0.7	Not Used (= 0)					
25	3	DB0.6...DB0.4	Fan speed	FAN	Fan Speed	Enum: 0: Auto 1: Speed 0 2: Speed 1 3: Speed 2 4: Speed 3 5: Speed 4 6: Speed 5 7: Off		
28	1	DB0.3	LRN Bit	LRNB	LRN Bit	Enum: 0: Teach-in telegram 1: Data telegram		
29	1	DB0.2	Not Used (= 0)					
30	1	DB0.1	Occupancy enable/disable	OED		Enum: 0: Occupancy enabled 1: Occupancy disabled		
31	1	DB0.0	Occupancy button	OB		Enum: 0: Button pressed 1: Button released		

A5-11: Controller Status

RORG	A5	4BS Telegram
FUNC	11	Controller Status
TYPE	01	Lighting Controller

Offset	Size	Bitrange	Data	ShortCut	Description	Valid Range	Scale	Unit
0	8	DB3.7...DB3.0	Illumination	ILL	Illumination (linear)	0...255	0...510	lx
8	8	DB2.7...DB2.0	Illumination Set Point	ISP	Illumination Set Point (Min. ... Max.) (linear)	0...255	0...255	N/A
16	8	DB1.7...DB1.0	Dimming Output Level	DIM	Dimming Output Level (Min. ... Max.) (linear)	0...255	0...255	N/A
24	1	DB0.7	Repeater	REP	Repeater	Enum: 0: disabled 1: enabled		

25	1	DB0.6	Power Relay Timer	PRT	Power Relay Timer	Enum: 0: disabled 1: enabled
26	1	DB0.5	Daylight Harvesting	DHV	Daylight Harvesting	Enum: 0: disabled 1: enabled
27	1	DB0.4	Dimming	EDIM	Dimming	Enum: 0: switching load 1: dimming load
28	1	DB0.3	LRN Bit	LRNB	LRN Bit	Enum: 0: Teach-in telegram 1: Data telegram
29	1	DB0.2	Magnet Contact	MGC	Magnet Contact	Enum: 0: open 1: closed
30	1	DB0.1	Occupancy	OCC	Occupancy	Enum: 0: unoccupied 1: occupied
31	1	DB0.0	Power Relay	PWR	Power Relay	Enum: 0: off 1: on

RORG	A5	4BS Telegram
FUNC	11	Controller Status
TYPE	02	Temperature Controller Output

Not approved

Offset	Size	Bitrange	Data	ShortCut	Description	Valid Range	Scale	Unit
0	8	DB3.7...DB3.0	Control Variable	CVAR	Actual value of controller	0...255	0...100	%
8	8	DB2.7...DB2.0	FanStage	FAN	Actual value of fan	Enum: 0: Stage 0 Manual 1: Stage 1 Manual 2: Stage 2 Manual 3: Stage 3 Manual 16: Stage 0 Automatic 17: Stage 1 Automatic 18: Stage 2 Automatic 19: Stage 3 Automatic 255: Not Available		
16	8	DB1.7...DB1.0	Actual Setpoint	ASP	Occupied: Basic setpoint occupied + Setpoint shift + Sensor offset StandBy: Basic setpoint standBy + Setpoint shift Unoccupied: Basic setpoint unoccupied + setpoint shift	0...255	0...+51.2	°C

24	1	DB0.7	Alarm	ALR	In case of internal error alarm is set	Enum: 0: No alarm 1: Alarm
25	2	DB0.6...DB0.5	Controller mode	CTM	Actual state of controller	Enum: 1: Heating 2: Cooling 3: Off
27	1	DB0.4	Controller state	CST	Automatic control, or is controlled from another device	Enum: 0: Automatic 1: Override
28	1	DB0.3	LRN Bit	LRNB	LRN Bit	Enum: 0: Teach-in telegram 1: Data telegram
29	1	DB0.2	Energy hold-off	ERH	Stop control if window is opened	Enum: 0: Normal 1: Energy hold-off/ Dew point
30	2	DB0.1...DB0.0	Room occupancy	RO	Actual room occupancy	Enum: 0: Occupied 1: Unoccupied 2: StandBy 3: Frost

A5-12: Automated meter reading (AMR)

The meter reading is represented by 3 data bytes, a divisor and a flag that indicates it as a cumulative or a current value. A 4 bit info field gives additional information and is TYPE specific.

RORG	A5	4BS Telegram
FUNC	12	Automated meter reading (AMR)
TYPE	00	Counter

Offset	Size	Bitrange	Data	ShortCut	Description	Valid Range	Scale	Unit
0	24	DB3.7...DB1.0	Meter reading	MR	Current value or cumulative counter value	0...16777215	according to DIV	according to DT
24	4	DB0.7...DB0.4	Measurement channel	CH		0...15	0...15	1
28	1	DB0.3	LRN Bit	LRNB	LRN Bit	Enum: 0: Teach-in telegram 1: Data telegram		
29	1	DB0.2	Data type (unit)	DT	Current value or cumulative counter value	Enum: 0: Cumulative value 1: Current value	1 1/s	
30	2	DB0.1...DB0.0	Divisor (scale)	DIV	Divisor for counter value	Enum: 0: x/1 1: x/10 2: x/100 3: x/1000		

RORG	A5	4BS Telegram
FUNC	12	Automated meter reading (AMR)
TYPE	01	Electricity

Offset	Size	Bitrange	Data	ShortCut	Description	Valid Range	Scale	Unit
0	24	DB3.7...DB1.0	Meter reading	MR	current value in W or cumulative value in kWh	0...16777215	according to DIV	according to DT
24	4	DB0.7...DB0.4	Tariff info	TI		0...15	0...15	1
28	1	DB0.3	LRN Bit	LRNB	LRN Bit	Enum: 0: Teach-in telegram 1: Data telegram		
29	1	DB0.2	Data type (unit)	DT	Current value or cumulative value	Enum: 0: Cumulative value kWh 1: Current value W		
30	2	DB0.1...DB0.0	Divisor (scale)	DIV	Divisor for value	Enum: 0: x/1 1: x/10 2: x/100 3: x/1000		

RORG	A5	4BS Telegram
FUNC	12	Automated meter reading (AMR)
TYPE	02	Gas

Offset	Size	Bitrange	Data	ShortCut	Description	Valid Range	Scale	Unit
0	24	DB3.7...DB1.0	meter reading	MR	Cumulative value in m ³ or Current value in liter/s	0...16777215	according to DIV	according to DT
24	4	DB0.7...DB0.4	Tariff info	TI		0...15	0...15	1
28	1	DB0.3	LRN Bit	LRNB	LRN Bit	Enum: 0: Teach-in telegram 1: Data telegram		
29	1	DB0.2	data type (unit)	DT	Current value or cumulative value	Enum: 0: Cumulative value m ³ 1: Current value liter/s		
30	2	DB0.1...DB0.0	divisor (scale)	DIV	Divisor for value	Enum: 0: x/1 1: x/10 2: x/100 3: x/1000		

RORG	A5	4BS Telegram
FUNC	12	Automated meter reading (AMR)
TYPE	03	Water

Offset	Size	Bitrange	Data	ShortCut	Description	Valid Range	Scale	Unit
0	24	DB3.7...DB1.0	Meter reading	MR	Cumulative value in m ³ or Current value in liter/s	0...16777215	according to DIV	according to DT
24	4	DB0.7...DB0.4	Tariff info	TI		0...15	0...15	1

28	1	DB0.3	LRN Bit	LRNB	LRN Bit	Enum: 0: Teach-in telegram 1: Data telegram
29	1	DB0.2	Data type (unit)	DT	Current value or cumulative value	Enum: 0: Cumulative value m ³ 1: Current value Liter/s
30	2	DB0.1...DB0.0	Divisor (scale)	DIV	Divisor for value	Enum: 0: x/1 1: x/10 2: x/100 3: x/1000

A5-13: Environmental Applications

RORG	A5	4BS Telegram
FUNC	13	Environmental Applications
TYPE	01	Weather Station

A receiver that accepts EEP A5-12-01 at teach-in automatically needs to accept telegrams from the same ID that comply to the definitions of EEP A5-13-02 thru EEP A5-13-06. Different telegrams received from that ID need to be distinguished by their 4 bit identifiers.

Offset	Size	Bitrange	Data	ShortCut	Description	Valid Range	Scale	Unit
0	8	DB3.7...DB3.0	Dawn sensor	DWS	Dawn sensor	0...255	0...999	lx
8	8	DB2.7...DB2.0	Temperature	TMP	Outdoor Temp	0...255	-40...+80	°C
16	8	DB1.7...DB1.0	Wind speed	WND	Wind speed	0...255	0...70	m/s
24	4	DB0.7...DB0.4	Identifier	ID	Identifier	Enum: 0x1:		
28	1	DB0.3	LRN Bit	LRNB	LRN Bit	Enum: 0: Teach-in telegram 1: Data telegram		
29	1	DB0.2	Day / Night	D/N	Day / Night	Enum: 0: Day 1: Night		
30	1	DB0.1	Rain Indication	RAN	Rain Indication	Enum: 0: No Rain 1: Rain		
31	1	DB0.0	Not Used (= 0)					

RORG	A5	4BS Telegram
FUNC	13	Environmental Applications
TYPE	02	Sun Intensity, Northern Hemisphere

Offset	Size	Bitrange	Data	ShortCut	Description	Valid Range	Scale	Unit
0	8	DB3.7...DB3.0	Sun - West	SNW	Sun - West,linear	0...255	1...150	klx
8	8	DB2.7...DB2.0	Sun - South	SNS	Sun - South,linear	0...255	1...150	klx
16	8	DB1.7...DB1.0	Sun - East	SNE	Sun - East,linear	0...255	1...150	klx
24	4	DB0.7...DB0.4	Identifier	ID	Identifier	Enum: 0x2:		
28	1	DB0.3	LRN Bit	LRNB	LRN Bit	Enum: 0: Teach-in telegram 1: Data telegram		

29	3	DB0.2...DB0.0	Not Used (= 0)
----	---	---------------	----------------

RORG	A5	4BS Telegram
FUNC	13	Environmental Applications
TYPE	03	Date Exchange

Offset	Size	Bitrange	Data	ShortCut	Description	Valid Range	Scale	Unit
0	3	DB3.7...DB3.5	Not Used (= 0)					
3	5	DB3.4...DB3.0	Day	DY	Day	1...31	1...31	N/A
8	4	DB2.7...DB2.4	Not Used (= 0)					
12	4	DB2.3...DB2.0	Month	MTH	Month (1->January)	1...12	1...12	N/A
16	1	DB1.7	Not Used (= 0)					
17	7	DB1.6...DB1.0	Year	YR	Year (0->Year 2000)	0...99	2000...2099	N/A
24	4	DB0.7...DB0.4	Identifier	ID	Identifier	Enum: 0x3:		
28	1	DB0.3	LRN Bit	LRNB	LRN Bit	Enum: 0: Teach-in telegram 1: Data telegram		
29	2	DB0.2...DB0.1	Not Used (= 0)					
31	1	DB0.0	Source	SRC	Source	Enum: 0: Real Time Clock 1: GPS or equivalent (e.g. DCF77, WWV)		

RORG	A5	4BS Telegram
FUNC	13	Environmental Applications
TYPE	04	Time and Day Exchange

Offset	Size	Bitrange	Data	ShortCut	Description	Valid Range	Scale	Unit
0	3	DB3.7...DB3.5	Weekday	WDY	Weekday (1 -> Monday)	Enum: 1: Monday 2: Tuesday 3: Wednesday 4: Thursday 5: Friday 6: Saturday 7: Sunday		
3	5	DB3.4...DB3.0	Hour	HR	Hour	0...23	0...23	N/A
8	2	DB2.7...DB2.6	Not Used (= 0)					
10	6	DB2.5...DB2.0	Minute	MIN	Minute	0...59	0...59	N/A
16	2	DB1.7...DB1.6	Not Used (= 0)					
18	6	DB1.5...DB1.0	Second	SEC	Second	0...59	0...59	N/A
24	4	DB0.7...DB0.4	Identifier	ID	Identifier	Enum: 0x4:		
28	1	DB0.3	LRN Bit	LRNB	LRN Bit	Enum: 0: Teach-in telegram 1: Data telegram		
29	1	DB0.2	Time Format	TMF	Time Format	Enum: 0: 24 hours 1: 12 hours		

30	1	DB0.1	AM/PM	A/PM	AM or PM	Enum: 0: AM 1: PM
31	1	DB0.0	Source	SRC	Source	Enum: 0: Real Time Clock 1: GPS or equivalent (e.g. DCF77, WWV)

RORG	A5	4BS Telegram
FUNC	13	Environmental Applications
TYPE	05	Direction Exchange

Offset	Size	Bitrange	Data	ShortCut	Description	Valid Range	Scale	Unit
0	8	DB3.7...DB3.0	Elevation	ELV	Elevation (0° -> Horizon)	0...180	-90...+90	°
15	9	DB2.0...DB1.0	Azimuth	AZM	Azimuth (0° -> True north)	0...359	0...359	°
24	4	DB0.7...DB0.4	Identifier	ID	Identifier	Enum: 0x5:		
28	1	DB0.3	LRN Bit	LRNB	LRN Bit	Enum: 0: Teach-in telegram 1: Data telegram		
29	3	DB0.2...DB0.0	Not Used (= 0)					

RORG	A5	4BS Telegram
FUNC	13	Environmental Applications
TYPE	06	Geographic Position Exchange

Offset	Size	Bitrange	Data	ShortCut	Description	Valid Range	Scale	Unit
0	4	DB3.7...DB3.4	Latitude(MSB)	LAT(MSB)	Latitude MSB	according to LAT(LSB)	according to LAT(LSB)	according to LAT(LSB)
4	4	DB3.3...DB3.0	Longitude(MSB)	LOT(MSB)	Longitude MSB	according to LOT(LSB)	according to LOT(LSB)	according to LOT(LSB)
8	8	DB2.7...DB2.0	Latitude(LSB)	LAT(LSB)	Latitude LSB	0...4095	-90...+90	°
16	8	DB1.7...DB1.0	Longitude(LSB)	LOT(LSB)	Longitude LSB	0...4095	-180...+180	°
24	4	DB0.7...DB0.4	Identifier	ID	Identifier	Enum: 0x6:		
28	1	DB0.3	LRN Bit	LRNB	LRN Bit	Enum: 0: Teach-in telegram 1: Data telegram		
29	3	DB0.2...DB0.0	Not Used (= 0)					

A5-20: HVAC Components

RORG	A5	4BS Telegram
FUNC	20	HVAC Components
TYPE	01	Battery Powered Actuator (Submitted by K+P) (BI-DIR)

DIRECTION-1 = Transmit mode: Message from the actuator to the controller

DIRECTION-2 = Receive mode: Commands from the controller to the actuator; transmit rate MAX = every second (<=

1 Hz)

DIRECTION-1

Offset	Size	Bitrange	Data	ShortCut	Description	Valid Range	Scale	Unit
0	8	DB3.7...DB3.0	Current Value	CV	Current value	0...100	0...100	%
8	1	DB2.7	Service On	SO	Service On	Enum: 1: on		
9	1	DB2.6	Energy input enabled	ENIE	Energy input enabled	Enum: 1: true		
10	1	DB2.5	Energy Storage	ES	Energy storage sufficiently charged	Enum: 1: true		
11	1	DB2.4	Battery capacity	BCAP	Battery capacity; change battery next days	Enum: 0: true		
12	1	DB2.3	Contact, cover open	CCO	Contact, cover open	Enum: 1: true		
13	1	DB2.2	Failure temperature sensor, out off range	FTS	Failure Temperature sensor, out off range	Enum: 1: true		
14	1	DB2.1	Detection, window open	DWO	Detection, window open	Enum: 1: true		
15	1	DB2.0	Actuator obstructed	ACO	Actuator obstructed	Enum: 1: true		
16	8	DB1.7...DB1.0	Temperature	TMP	Temperature (linear)	0...255	0...+40	°C
24	4	DB0.7...DB0.4	Not Used (= 0)					
28	1	DB0.3	LRN Bit	LRNB	LRN Bit	Enum: 0: Teach-in telegram 1: Data telegram		
29	3	DB0.2...DB0.0	Not Used (= 0)					

DIRECTION-2

Offset	Size	Bitrange	Data	ShortCut	Description	Valid Range	Scale	Unit
0	8	DB3.7...DB3.0	Valve position or Temperature Setpoint	SP	Valve position or Temperature set point (linear); selection with DB1.2 Valve position 0...100% in combination with compatible classic controllers the actuator used DB_3; Temperature set point: The actuator can be used as self-sufficient room controller (pi controller) without integration in automation systems. Wherever the user wants room conditions to be individually controlled, the actuator can work in combination with a wireless room device (RCU).	0...100 or 255	0...100 or +40	% or °C
8	8	DB2.7...DB2.0	Temperature from RCU	TMP	Temperature actual from RCU = 0b0 (Room controller-unit), see DB1.0 Maintenance mode ("service on"): DB_2.BIT_5: energy memory sufficiently charged =1 DB_2.BIT_4: battery capacity changing battery in the next days, need changing batteries = 0 Status feedback signal (service on, DB_2.BIT_7	255...0	0...+40	°C

16	1	DB1.7	Run init sequence	RIN	The limit switching measures the travel and signals when an end position has been reached. This end position (valve zero point) in the actuator is stored.	Enum: 1: true
17	1	DB1.6	Lift set	LFS	Initialization, adjustment to the valve stroke. The Initialization is switched after receiving the command. The valve is completely opened and closed during initialization.	Enum: 1: true
18	1	DB1.5	Valve open / maintenance	VO	After receiving an operation command, the actuator moves the valve in direction open or close. when reaching the end position, an automatic switch-off procedure is started. In service mode the valve can be set to open or closed always.	Enum: 1: true
19	1	DB1.4	Valve closed	VC	valve closed	Enum: 1: true
20	1	DB1.3	Summer bit, Reduction of energy consumption	SB	The radio communication between the actuator and the controller is restricted, sleep mode is extended. This functionality can be used for battery powered actuators.	Enum: 1: true
21	1	DB1.2	Set Point Selection	SPS	Set Point Selection for DB3	Enum: 0: Valve position (0-100%). Unit respond to controller. 1: Temperature set point 0...40°C. Unit respond to room sensor and use internal PI loop.
22	1	DB1.1	Set point inverse	SPN	Valve set point can be sent to the actuator normal or inverted. The selection is done by DB_1.Bit1. The implementation is done and is controlled in the actuator with DB_3. This function is used in dependence on the type of valve.	Enum: 1: true
23	1	DB1.0	Select function	RCU	RCU or "Service on": After transmitting the command to the actuator, it can be send from the controller or a service device, the actuator sends a status feedback signal (service on, DB_2.BIT_7).	Enum: 0: RCU 1: service on
24	4	DB0.7...DB0.4	Not Used (= 0)			
28	1	DB0.3	LRN Bit	LRNB	LRN Bit	Enum: 0: Teach-in telegram 1: Data telegram
29	3	DB0.2...DB0.0	Not Used (= 0)			

RORG	A5	4BS Telegram
FUNC	20	HVAC Components
TYPE	02	Basic Actuator (Submitted by Spartan) (BI-DIR)

Basic Actuator can be used by any manufacturer for linear or rotary actuator.
DIRECTION-1 = Transmit mode: Message from the actuator to the controller.
DIRECTION-2 = Receive mode: Commands from the controller to the actuator. To use with a BAS/Gateway system transmit rate MAX= every second (≤ 1 Hz).

DIRECTION-1

Offset	Size	Bitrange	Data	ShortCut	Description	Valid Range	Scale	Unit
0	8	DB3.7...DB3.0	Actual Value	AV	Actual value (linear); can be a linear or rotation motion.	0...100	0...100	%
8	14	DB2.7...DB1.2	Not Used (= 0)					
22	1	DB1.1	Set point inverse	SPI	Set point inverse (Needs to be defined by manufacturer what zero(0) is equal to, and one(1) is equal to. Default state to be define as per product manufacturer	Enum: 1: true		
24	4	DB0.7...DB0.4	Not Used (= 0)					
28	1	DB0.3	LRN Bit	LRNB	LRN Bit	Enum: 0: Teach-in telegram 1: Data telegram		
29	3	DB0.2...DB0.0	Not Used (= 0)					

DIRECTION-2

Offset	Size	Bitrange	Data	ShortCut	Description	Valid Range	Scale	Unit
0	8	DB3.7...DB3.0	Valve Set point	VSP	Valve set Point (linear)	0...100	0...100	%
8	8	DB2.7...DB2.0	Not Used (= 0)					
16	6	DB1.7...DB1.2	Not Used (= 0)					
22	1	DB1.1	Set point inverse	VSP	"Set point inverse " needs to be defined by manufacturer what zero(0) is equal to, and one(1) is equal to. Default state to be define as per product manufacturer. It can send a command to invert functionality of the unit. In some instance some equipment might need 100% to represent fully extracted, in other fully retracted.	Enum: 1: true		
23	5	DB1.0...DB0.4	Not Used (= 0)					
28	1	DB0.3	LRN Bit	LRNB	LRN Bit	Enum: 0: Teach-in telegram 1: Data telegram		
29	3	DB0.2...DB0.0	Not Used (= 0)					

RORG	A5	4BS Telegram
FUNC	20	HVAC Components
TYPE	03	Line powered Actuator (Submitted by Spartan) (BI-DIR)

DIRECTION-1 = Transmit mode: Message from the actuator to the controller.

DIRECTION-2 = Receive mode: Commands from the controller to the actuator. Transmit rate MAX = every second (<= 1 Hz).

DIRECTION-1

Offset	Size	Bitrange	Data	ShortCut	Description	Valid Range	Scale	Unit
0	8	DB3.7...DB3.0	Actual valve	AV	Actual valve	0...100	0...100	%
8	8	DB2.7...DB2.0	Not Used (= 0)					
16	8	DB1.7...DB1.0	Temperature	TMP	Temperature (linear)	0...255	0...+40	°C
23	5	DB1.0...DB0.4	Not Used (= 0)					
28	1	DB0.3	LRN Bit	LRNB	LRN Bit	Enum: 0: Teach-in telegram 1: Data telegram		
29	3	DB0.2...DB0.0	Not Used (= 0)					

DIRECTION-2

Offset	Size	Bitrange	Data	ShortCut	Description	Valid Range	Scale	Unit
0	8	DB3.7...DB3.0	Actuator or Temperature Setpoint	ATS	Actuator Setpoint: in combination with BAS/Gateway controllers. Temperature Setpoint: The actuator can be used as self-sufficient room controller (pi controller) without integration in automation systems. Wherever the user wants room conditions to be individually controlled, the actuator can work in combination with a wireless room device (RCU).	0...100 or 255	0...100 or +40	% or °C
8	8	DB2.7...DB2.0	Temperature from RCU	TMPRC	Temperature actual from RCU = 0b0 (Room controller-unit)	255...0	0...+40	°C
16	5	DB1.7...DB1.3	Not Used (= 0)					
21	1	DB1.2	Set Point Selection	SPS	Set Point Selection for DB3	Enum: 0: Actuator Setpoint (0-100%); Unit respond to controller. 1: Temperature Setpoint 0...+40°C; Unit respond to room sensor and use internal PI loop.		
22	1	DB1.1	Set Point Inverse		Valve set point can be sent to the actuator normal or inverted through BAS/Gateway controller. The selection is done by DB_1.Bit1. in the actuator with DB_3. This function is used in dependence on the type of valve.	Enum: 1: true		
23	5	DB1.0...DB0.4	Not Used (= 0)					
28	1	DB0.3	LRN Bit	LRNB	LRN Bit	Enum: 0: Teach-in telegram 1: Data telegram		
29	3	DB0.2...DB0.0	Not Used (= 0)					

RORG	FUNC	TYPE	A5	4BS Telegram
			20	HVAC Components
			10	Generic HVAC Interface (Submitted by Intesis) (BI-DIR)

Functions: Mode, Vane Position, Fan Speed, Sensors and On/Off: With this EEP plus the already existing EEP A5-10-03 and A5-20-11 all the information of AC indoor unit can be sent and received allowing a much easier and complete control of these units.

DIRECTION-1 = Receive mode: Commands received by the HVAC interface.

DIRECTION-2 = Transmit mode: Commands sent by the HVAC interface.

DIRECTION-1

Offset	Size	Bitrange	Data	ShortCut	Description	Valid Range	Scale	Unit
0	8	DB3.7...DB3.0	Mode	MD	The modes are the same as in KNX and LON allowing a more transparent integration with this protocols and it has plenty of free positions for future expansion	Enum: 0: Auto 1: Heat 2: Morning Warmup 3: Cool 4: Night Purge 5: Precool 6: Off		

										7: Test
										8: Emergency Heat
										9: Fan only
										10: Free cool
										11: Ice
										12: Max heat
										13: Economic heat/cool
										14: Dehumidification (dry)
										15: Calibration
										16: Emergency cool
										17: Emergency steam
										18: max cool
										19: Hvc load
										20: no load
										reserved
										21...30:
										31: Auto Heat
										32: Auto Cool
										reserved
										33...254:
										255: N/A
8	4	DB2.7...DB2.4	Vane position	VPS						Enum:
										0: Auto
										1: Horizontal
										2: Pos2
										3: Pos3
										4: Pos4
										5: Vertical
										6: Swing
										Reserved
										7...10:
										11: Vertical swing
										12: Horizontal swing
										13: Horizontal and vertical swing
										14: Stop swing
										15: N/A
12	4	DB2.3...DB2.0	Fan Speed	FANSP	fan speed value goes from 1 to 14. 1 is the lowest fan speed allowed by the AC and from there it increments with the value of this variable. Typically AC units have up to 5-6 speeds. Any speed higher than the maximum the AC allows would set it to the higher speed. 0 is auto and 15 is N/A					Enum:
										0: Auto
										Up to 14 fan speeds
										1...14: being 1 the lowest
										15: N/A
16	8	DB1.7...DB1.0	Control variable	CVAR	Control variable; value 255 = auto			0...100, 255	0...100	%
24	4	DB0.7...DB0.4	Not Used (= 0)							
28	1	DB0.3	LRN Bit	LRNB	LRN Bit					Enum:
										0: Teach-in telegram
										1: Data telegram
29	2	DB0.2...DB0.1	Room occupancy	RO	The interfaces can automatically control the behaviour of the AC without integration in automation systems when linked to presence/movement sensors.					Enum:
										0: Occupied
										1: StandBy (waiting to perform action)
										2: Unoccupied (action performed)
										3: Off (no occupancy and no action)

31	1	DB0.0	On/Off	O/I	On/Off	Enum:
						0: off (the unit is not running)
						1: on

DIRECTION-2

Offset	Size	Bitrange	Data	ShortCut	Description	Valid Range	Scale	Unit
0	8	DB3.7...DB3.0	Mode	MD	The modes are the same as in KNX and LON allowing a more transparent integration with this protocols and it has plenty of free positions for future expansion	Enum:		
						0: Auto		
						1: Heat		
						2: Morning Warmup		
						3: Cool		
						4: Night Purge		
						5: Precool		
						6: Off		
						7: Test		
						8: Emergency Heat		
						9: Fan only		
						10: Free cool		
						11: Ice		
						12: Max heat		
						13: Economic heat/cool		
						14: Dehumidification (dry)		
						15: Calibration		
						16: Emergency cool		
						17: Emergency steam		
						18: max cool		
						19: Hvc load		
						20: no load		
						reserved		
						21...30:		
						31: Auto Heat		
						32: Auto Cool		
						reserved		
						33...254:		
						255: N/A		
8	4	DB2.7...DB2.4	Vane position	VPS		Enum:		
						0: Auto		
						1: Horizontal		
						2: Pos2		
						3: Pos3		
						4: Pos4		
						5: Vertical		
						6: Swing		
						Reserved		
						7...10:		
						11: Vertical swing		
						12: Horizontal swing		
						13: Horizontal and vertical swing		
						14: Stop swing		
						15: N/A		
12	4	DB2.3...DB2.0	Fan Speed	FANSP	fan speed value goes from 1 to 14. 1 is the lowest fan speed allowed by the AC and from there it increments with the value of this variable. Typically AC units have up to 5-6 speeds. Any speed higher than the maximum the AC allows would set it to the higher speed. 0 is auto and 15 is N/A	Enum:		
						0: Auto		
						Up to 14 fan speeds		
						1...14: being 1 the lowest		
						15: N/A		

16	8	DB1.7...DB1.0	Control variable	CVAR	Control variable (linear); value 255 = auto	0...100, 255	0...100	%
24	4	DB0.7...DB0.4	Not Used (= 0)					
28	1	DB0.3	LRN Bit	LRNB	LRN Bit	Enum: 0: Teach-in telegram 1: Data telegram		
29	2	DB0.2...DB0.1	Room occupancy	RO	Room occupancy	Enum: 0: Occupied 1: StandBy (waiting to perform action) 2: Unoccupied (action performed) 3: Off (no occupancy and no action)		
31	1	DB0.0	On/Off	O/I	On/Off	Enum: 0: off 1: on		

RORG	A5	4BS Telegram
FUNC	20	HVAC Components
TYPE	11	Generic HVAC Interface - Error Control (Submitted by Intesis) (BI-DIR)

Error Control: AC Error Code, Error States and Disablements. With this EEP plus the already existing EEP A5-10-03 and A5-20-10 all the information of AC indoor unit can be sent and received allowing a much easier and complete control of these units.

DIRECTION-1 = Receive mode: Commands received by the HVAC interface.

DIRECTION-2 = Transmit mode: Commands sent by the HVAC interface.

DIRECTION-1

Offset	Size	Bitrange	Data	ShortCut	Description	Valid Range	Scale	Unit
0	23	DB3.7...DB1.1	Not Used (= 0)					
23	1	DB1.0	External disablement	EXDS	External disablement	Enum: 0: Not disabled 1: Disabled		
24	4	DB0.7...DB0.4	Not Used (= 0)					
28	1	DB0.3	LRN Bit	LRNB	LRN Bit	Enum: 0: Teach-in telegram 1: Data telegram		
29	1	DB0.2	Disable remote controller	DRC	Disable remote controller (When in receive mode it controls if the interface overwrites the remote controller commands.)	Enum: 0: Enable Remote controller 1: Disable Remote controller		
30	1	DB0.1	Window contact	WC	Window contact	Enum: 0: Windows opened 1: Windows closed		
31	1	DB0.0	Not Used (= 0)					

DIRECTION-2

Offset	Size	Bitrange	Data	ShortCut	Description	Valid Range	Scale	Unit
0	16	DB3.7...DB2.0	Error Code	ERR	Error Code (DB3 HI, DB2 LO); generated by A.C.	0...65535	0...65535	N/A

16	4	DB1.7...DB1.4	Reserved	RES	Reserved (0b0000)	Enum: : Reserved
20	1	DB1.3	Other disablement	OD	Manufacturer defined. It is just to provide an extra "disablement signal" that could be used for other devices. People would not have to change anything then as this is already an established "signal"	Enum: 0: Not disabled 1: Disabled
21	1	DB1.2	Window contact disablement	WCD	Window contact disablement	Enum: 0: Not disabled 1: Disabled
22	1	DB1.1	Key card disablement	KCD	Key card disablement	Enum: 0: Not disabled 1: Disabled
23	1	DB1.0	External disablement	ED	External disablement	Enum: 0: Not disabled 1: Disabled
24	4	DB0.7...DB0.4	Not Used (= 0)			
28	1	DB0.3	LRN Bit	LRNB	LRN Bit	Enum: 0: Teach-in telegram 1: Data telegram
29	1	DB0.2	Remote controller Disablement	RCD	Remote controller Disablement (In transmit it sends the status of this parameter. If the manufacturer doesn't support this option, it will send always 0, no matter what it receives.)	Enum: 0: Remote controller enabled 1: Remote controller disabled
30	1	DB0.1	Window contact	WC	Window contact	Enum: 0: Windows opened 1: Windows closed
31	1	DB0.0	Alarm State	AS	Alarm State	Enum: 0: Ok 1: Error

RORG	A5	4BS Telegram
FUNC	20	HVAC Components
TYPE	12	Temperature Controller Input

Offset	Size	Bitrange	Data	ShortCut	Description	Valid Range	Scale	Unit
0	8	DB3.7...DB3.0	Control Variable override	CV	Actual value for controller	0...255	0...100	%
8	8	DB2.7...DB2.0	FanStage override	FANOR	FanStage override	Enum: 0: Stage 0 1: Stage 1 2: Stage 2 3: Stage 3 31: auto 255: not available		
16	8	DB1.7...DB1.0	Setpoint shift	SPS	Actual set point could be shifted	0...255	-10...+10	°K
24	1	DB0.7	Fan override	FANOR		Enum: 0: Automatic 1: Override Fan DB2		

25	2	DB0.6...DB0.5	Controller mode	CTM		Enum: 0: Auto mode 1: Heating 2: Cooling 3: Off
27	1	DB0.4	Controller state	CST	Controller state	Enum: 0: Automatic 1: Override control variable DB3
28	1	DB0.3	LRN Bit	LRNB	LRN Bit	Enum: 0: Teach-in telegram 1: Data telegram
29	1	DB0.2	Energy hold-off / Dew point	ERH	Energy hold-off / Dew point	Enum: 0: Normal 1: Energy hold-off/ Dew point
30	2	DB0.1...DB0.0	Room occupancy	RO	Actual room occupancy	Enum: 0: Internal room occupancy 1: Unoccupied 2: StandBy 3: Frost

A5-30: Digital Input

RORG	A5	4BS Telegram
FUNC	30	Digital Input
TYPE	01	Single Input Contact, Battery Monitor

Offset	Size	Bitrange	Data	ShortCut	Description	Valid Range	Scale	Unit
0	8	DB3.7...DB3.0	Not Used (= 0)					
8	8	DB2.7...DB2.0	Supply voltage	SVC	Supply voltage (linear)	Enum: 0...120: Battery LOW 121...255: Battery OK		
16	8	DB1.7...DB1.0	Input State	IPS	Input State	Enum: 0...195: Contact closed 196...255: Contact open		
24	4	DB0.7...DB0.4	Not Used (= 0)					
28	1	DB0.3	LRN Bit	LRNB	LRN Bit	Enum: 0: Teach-in telegram 1: Data telegram		
29	3	DB0.2...DB0.0	Not Used (= 0)					

RORG	A5	4BS Telegram
FUNC	30	Digital Input
TYPE	02	Single Input Contact

Offset	Size	Bitrange	Data	ShortCut	Description	Valid Range	Scale	Unit
0	28	DB3.7...DB0.4	Not Used (= 0)					

28	1	DB0.3	LRN Bit	LRNB	LRN Bit	Enum:
						0: Teach-in telegram
						1: Data telegram
29	2	DB0.2...DB0.1	Not Used (= 0)			
31	1	DB0.0	Input State	IPS	Input State	Enum:
						0: Contact closed
						1: Contact open

A5-37: Energy Management

RORG	A5	4BS Telegram
FUNC	37	Energy Management
TYPE	01	Demand Response

Purpose of EEP:

Demand Response is a developing standard to allow utility companies to send requests for reduction in power consumption during peak usage times. It is also used as a means to allow users to reduce overall power consumption as energy prices increase. Having an EEP for this will allow ease of integration with EnOcean products to this standard. The EEP was designed with a very flexible setting for the level (0-15) as well as a default level whereby the transmitter can specify a specific level for all controllers to use (0-100% of either maximum or current power output, depending on the load type). This EEP also includes a timeout setting to indicate how long the DR event should last if the DR transmitting device does not send heartbeats or subsequent new DR levels.

Description:

This EEP is included under a new function of Energy Management. Additional types could be added in future for power, voltage, and current data. The proposed EEP type 01 only deals with demand response activation at this point. Data Byte 3 is the default DR value for devices that implement a control algorithm that uses a set-point. It will be used for any controllers not supporting the current DR Level in the message and having an adjustable set-point.

Data Byte 2 is the default DR Level for any controllers not supporting the current DR Level in the message and having an adjustable control. It can be defined as either a percentage of the maximum power or a percentage of the current power, depending on the value of bit 7 in Data Byte 2. Bits 0 through 6 contain the percentage of power (either relative or absolute) that should be used. A value of 0 corresponds to 0% and a value of 100 corresponds to 100%. Any value higher than 100 should be interpreted as 100%. For example, if the current DR level is not supported by the controller and Data Byte 2 bit 7 is 0 and Data Byte 2 bits 0 through 6 are set to 55, then the controller should try to use 55% of its maximum power usage. In the case of a lighting load with 0-10V dimming, this would correspond to 5.5V on the dimming line. In the case of a heating controller with a maximum set back of 5 degrees C, this would correspond to a set back of 2.75 degrees C (this would most likely be rounded to 3).

Data Byte 1 is the timeout for this DR event. After this command is sent the controller will stay at the DR level for Data Byte 1 multiplied by 15 minutes. Once this time has elapsed the controller will return to normal operation. If Data Byte 1 is 0 then the controller will remain in the DR event until the next DR command is received. This timeout allows DR devices to leave or turn off after setting controllers into a DR state, thus the DR transmitter is not needed to take the devices out of the DR state and the controllers will automatically recover. For example a DR transmitter that only sends messages when a DR event is active could be used with the timeout to create a successful DR system.

Data Byte 0, Bits 7 through 4 make up a nibble that will be used as the DR level. Levels 0 through 15 will be possible using these bits. Bit 4 will be the lowest bit in this nibble and bit 7 will be the highest. If any level is not supported by a controller then that controller should use the default settings sent in this message or map the level to one that it supports.

Data Byte 0 Bits 2 and 1 indicate whether the power adjustment at start and end of the DR event should be randomized or not. This feature is intended to minimize rapid changes on the power distribution equipment by delaying each controller's response. If random start or end is enabled, each controller will delay starting or ending the DR event by a random time that will vary uniformly over a specific time period (for example, 5 seconds, 60 seconds, or 15 minutes).. The maximum length of these random delays will depend on the implementation in the controller.

Data Byte 0, Bit 0 is the state for loads that are not adjustable for the default DR level. If a controller does not support the current DR level and does not have adjustable control then it should use this bit. The two states of this bit are defined as follows: 1 = maximum power usage by controller, 0 = minimum power usage by the controller. If for example lights are being controlled, then a setting of 1 will mean the lights should be ON, whereas a setting of 0 will mean the lights should be OFF. For a thermostat application with non adjustable set back, a setting of 1 will mean that no set back should be applied, whereas a setting of 0 will mean that the full set back should be applied. This setting only applies to the maximum power usage of the controller, if for example the lights are currently off and the controller receives a DR event with this bit set, then the lights should not turn ON as the DR event has only set the maximum power usage for the device.

Offset	Size	Bitrange	Data	ShortCut	Description	Valid Range	Scale	Unit
0	8	DB3.7...DB3.0	Temporary default	TMPD	New Temporary default DR set point Min. ... Max. (linear)	0...255	0...255	N/A
8	1	DB2.7	Absolute/relative power usage	SPWRU		Enum: 0: Absolute power usage. Interpret DB_2.BIT_6...DB_2.BIT_0 as a percentage of the maximum power use. 1: Relative power usage. Interpret DB_2.BIT_6...DB_2.BIT_0 as a percentage of the current power use.		
9	7	DB2.6...DB2.0	Power Usage	PWRU	0% to 100% power usage in 1% increments; 101...127 = interpreted as 100%	0...100	0...100	N/A
16	8	DB1.7...DB1.0	Timeout Setting	TMOS	Time in 15 min. intervals; 0 = No time specified; 1...255 = increasing 15 min. intervals. Max value: 3825 = 255*15	1...255	15...3825	min
24	4	DB0.7...DB0.4	DR Level	DRL	DR Level	0...15	0...15	N/A
28	1	DB0.3	LRN Bit	LRNB	LRN Bit	Enum: 0: Teach-in telegram 1: Data telegram		
29	1	DB0.2	Random start delay	RSD	...	Enum: 0: False 1: True		
30	1	DB0.1	Randomized end delay	RED	...	Enum: 0: False 1: True		
31	1	DB0.0	Max/Min Power Usage for Default DR State	MPWRU		Enum: 0: Minimum Power usage 1: Maximum Power usage		

A5-38: Central Command

RORG	A5	4BS Telegram
FUNC	38	Central Command
TYPE	08	PHC Gateway

Communication between gateway and actuator uses byte DB_3 to identify Commands. Commands 0x01 to 0x7F shall be common to all types belonging to this profile. Commands 0x80 to 0xFE can be defined individually for each device type.

0x01 Switching

Offset	Size	Bitrange	Data	ShortCut	Description	Valid Range	Scale	Unit
--------	------	----------	------	----------	-------------	-------------	-------	------

0	8	DB3.7...DB3.0	Command	COM	Command ID	Enum: 0x01:
8	16	DB2.7...DB1.0	Time	TIM	Time in 1/10 seconds. 0 = no time specified	1...65535 0.1...6553.5s
24	4	DB0.7...DB0.4	Not Used (= 0)			
28	1	DB0.3	LRN Bit	LRNB	LRN Bit	Enum: 0: Teach-in telegram 1: Data telegram
29	1	DB0.2	Lock/Unlock	LCK	Lock for duration time if time >0, unlimited time of no time specified. Locking may be cleared with „unlock“. During lock phase no other commands will be accepted or executed	Enum: 0: Unlock 1: Lock
30	1	DB0.1	Delay or duration	DEL	Delay or duration (if Time > 0); 0 = Duration (Execute switching command immediately and switch back after duration) 1 = Delay (Execute switching command after delay)	Enum: 0: Duration 1: Delay
31	1	DB0.0	Switching Command	SW	Switching Command ON/OFF	Enum: 0: Off 1: On

0x02 Dimming

Offset	Size	Bitrange	Data	ShortCut	Description	Valid Range	Scale	Unit
0	8	DB3.7...DB3.0	Command	COM	Command ID	Enum: 0x02:		
8	8	DB2.7...DB2.0	Dimming value	EDIM	Dimming value (absolute [0...255] or relative [0...100])	0...255	0...100	%
16	8	DB1.7...DB1.0	Ramping time	RMP	Ramping time in seconds, 0 = no ramping, 1... 255 = seconds to 100%	0...255	0...255	s
24	4	DB0.7...DB0.4	Not Used (= 0)					
28	1	DB0.3	LRN Bit	LRNB	LRN Bit	Enum: 0: Teach-in telegram 1: Data telegram		
29	1	DB0.2	Dimming Range	EDIM R	Dimming Range	Enum: 0: Absolute value 1: Relative value		
30	1	DB0.1	Store final value	STR	Store final value	Enum: 0: No 1: Yes		
31	1	DB0.0	Switching Command	SW	Switching Command ON/OFF	Enum: 0: Off 1: On		

0x03 Setpoint shift

Used for changing set point, for example summer / winter compensation

Offset	Size	Bitrange	Data	ShortCut	Description	Valid Range	Scale	Unit
0	8	DB3.7...DB3.0	Command	COM	Command ID	Enum: 0x03:		

8	8	DB2.7...DB2.0	Not Used (= 0)					
16	8	DB1.7...DB1.0	Setpoint	SP	Setpoint shift	0...255	-12.7...12.8	K
24	4	DB0.7...DB0.4	Not Used (= 0)					
28	1	DB0.3	LRN Bit	LRNB	LRN Bit	Enum: 0: Teach-in telegram 1: Data telegram		
29	3	DB0.2...DB0.0	Not Used (= 0)					

0x04 Basic Setpoint

Send a new basic set point via DDC to an actuator

Offset	Size	Bitrange	Data	ShortCut	Description	Valid Range	Scale	Unit	
0	8	DB3.7...DB3.0	Command	COM	Command ID	Enum: 0x04:			
8	8	DB2.7...DB2.0	Not Used (= 0)						
16	8	DB1.7...DB1.0	Basic Setpoint	BSP	Basic Setpoint	0...255	0...+51.2	°C	
24	4	DB0.7...DB0.4	Not Used (= 0)						
28	1	DB0.3	LRN Bit	LRNB	LRN Bit	Enum: 0: Teach-in telegram 1: Data telegram			
29	3	DB0.2...DB0.0	Not Used (= 0)						

0x05 Control variable

Set occupancy, energy holdoff and control directly actuator

Offset	Size	Bitrange	Data	ShortCut	Description	Valid Range	Scale	Unit	
0	8	DB3.7...DB3.0	Command	COM	Command ID	Enum: 0x05:			
8	8	DB2.7...DB2.0	Not Used (= 0)						
16	8	DB1.7...DB1.0	Control variable override	CVOV	Control variable override	0...255	0...100	%	
24	1	DB0.7	Not Used (= 0)						
25	2	DB0.6...DB0.5	Controller mode	CM	Controller Mode	Enum: 0: Automatic mode selection 1: Heating 2: Cooling 3: Off			
27	1	DB0.4	Controller state	CS	Controller state	Enum: 0: Automatic 1: Override			
28	1	DB0.3	LRN Bit	LRNB	LRN Bit	Enum: 0: Teach-in telegram 1: Data telegram			
29	1	DB0.2	Energy hold off	ENHO	Energy Hold Off	Enum: 0: Normal 1: Energy holdoff/ Dew point			
30	2	DB0.1...DB0.0	Room occupancy	RMOCC	Room occupancy	Enum: 0: Occupied 1: Unoccupied 2: Standby			

0x06 Fan stage

Set directly fan stage

Offset	Size	Bitrange	Data	ShortCut	Description	Valid Range	Scale	Unit
0	8	DB3.7...DB3.0	Command	COM	Command ID	Enum: 0x06:		
8	8	DB2.7...DB2.0	Not Used (= 0)					
16	8	DB1.7...DB1.0	FanStage override	FO	FanStage override	Enum: 0: Stage 0 1: Stage 1 2: Stage 2 3: Stage 3 255: Auto		
24	4	DB0.7...DB0.4	Not Used (= 0)					
28	1	DB0.3	LRN Bit	LRNB	LRN Bit	Enum: 0: Teach-in telegram 1: Data telegram		
29	3	DB0.2...DB0.0	Not Used (= 0)					

A5-3F: Universal

RORG	A5	4BS Telegram
FUNC	3F	Universal
TYPE	00	Radio Link Test (BI-DIR)

Units supporting the EEP Radio Link Test shall offer a functionality that allows for radio link testing between them (Position A to Position B, point-to-point only). Testing shall be possible without the need for prior teach-in and as an option it shall cover two way communications.

Further, testing shall be backward compatible to existing EnOcean installations that support at least 1BS (RORG=0xD5) and 4BS (RORG=0xA5) EnOcean messages.

The main area of RLT application are in-field testing of radio links between portable test equipment placed at different locations as well as between portable test equipment and fixed installation, e.g. an EnOcean Gateway.

Functional description of RLT:

When two units perform radio link testing one unit needs to act in a mode called RLT Master and the other unit needs to act in a mode called RLT Slave. On a RLT enabled unit one or both modes may be supported. The mode(s) supported shall require explicitly activation at run time.

After activation a RLT Master listens for RLT_Query messages. On reception of at least one RLT_Query message a RLT Master responds with an RLT_Response message. Following that it starts transmission of RLT_MasterTest messages within a maximum time frame of 250ms and awaits the response from the RLT Slave for each RLT_MasterTest message sent. A radio link test communication consists of a minimum of 16 and a maximum of 256 RLT_MasterTest messages. Timing distance between individual RLT_MasterTest messages shall not exceed 250ms. When the radio link test communication is completed the RLT Master gets deactivated automatically.

After activation a RLT Slave periodically transmits RLT_Query messages (1 message / 2s). It stops transmission of RLT_Query messages as soon as it has received at least one RLT_Response message. It then waits for RLT_MasterTest messages from the same EnOcean ID and replies to them within a maximum delay of 100ms thru RLT_SlaveTest messages. If it does not receive RLT_MasterTest messages from the same EnOcean ID for a time period of 5s, the RLT Slave restarts periodic transmission of RLT_Query messages. The RLT Slave requires explicit deactivation.

RLT_Query Message

This Message is a "4BS Teach-In Query" message with FUNC, Type and Manufacturer ID set properly. For details please refer to the description of the 4BS teach-in process.

RLT_Response Message

This Message is a "4BS Teach-In Response" message with FUNC, Type and Manufacturer ID set properly. For details please refer to the description of the 4BS teach-in process. As a RLT Master does accept teach-in of a RLT Slave only for the time period required by a single RLT communication it shall indicate the EEP to be supported but the EnOcean ID of the RLT Slave not to be stored permanently.

RLT_MasterTest_4BS

This is the 4BS message sent by the RLT Master during a radio link test communication

DIRECTION- 1

Offset	Size	Bitrange	Data	ShortCut	Description	Valid Range	Scale	Unit
0	28	DB3.7...DB0.4	Not Used (= 0)					
28	1	DB0.3	LRN Bit	LRNB	LRN Bit	Enum:		
						0:	Teach-in telegram	
						1:	Data telegram	
29	2	DB0.2...DB0.1	MSG_ID	MSGID	Message ID	Enum:		
						2:		
31	1	DB0.0	MSG-Source	MSGS	Message Source	Enum:		
						0:	RLT-Master	

RLT_SlaveTest_4BS

This is the 4BS message sent by the RLT Slave in reply to an RLT_MasterTest_4BS message.

DIRECTION- 2

Offset	Size	Bitrange	Data	ShortCut	Description	Valid Range	Scale	Unit
0	2	DB3.7...DB3.6	Sub-Telegram Counter	STCNT	related to RLT_MasterTest_4BS message received Repeater level 2	Enum:		
						0:	not supported	
						1:	1 sub telegram	
						2:	2 sub telegram	
						3:	≥ 3 sub telegram	
2	6	DB3.5...DB3.0	RSSI Level in dBm	RSLV	related to RLT_MasterTest_4BS message received Repeater level 1	Enum:		
						not supported		
						0x00:	supported	
						≥ -31	dBm	
						0x01:	-32	dBm
						0x02:	≤ -93	dBm
						0x3F:		
8	8	DB2.7...DB2.0	Sub-Telegram Counter/RSSI Level in dBm	RSLV	Related to RLT_MasterTest_4BS message received Repeater level 1 (for details see DB3)	Enum:		
						:	See prev	
16	8	DB1.7...DB1.0	Sub-Telegram Counter/RSSI Level in dBm	RSLV	Related to RLT_MasterTest_4BS message received direct link	Enum:		
						:	See prev	
24	4	DB0.7...DB0.4	RSSI Level in dBm	RSLV	Non-EnOcean signal detection since last RLT_MasterTest message RSSI Level with 6dB quantization steps	Enum:		
						not supported		
						0x00:	supported	
						≥ -31	dBm	
						0x01:	-32...-37	dBm
						0x02:	-38...-43	dBm
						0x03:	-44...-49	dBm
						0x04:	-50...-55	dBm
						0x05:	-56...-61	dBm
						0x06:	-62...-67	dBm
						0x07:	-68...-73	dBm
						0x08:		

						-74...-79 dBm
						0x09: -80...-85 dBm
						0x0A: ≤ -92 dBm
						0x0B: Enum:
						0: Teach-in telegram
						1: Data telegram
28	1	DB0.3	LRN Bit	LRNB	LRN Bit	Enum:
						0: Teach-in telegram
						1: Data telegram
29	2	DB0.2...DB0.1	MSG_ID	MSGID		Enum:
						2: _____
31	1	DB0.0	MSG-Source	MSGS		Enum:
						1: RLT-Slave

RLT_MasterTest_1BS

This is the 1BS message sent by the RLT Master during a radio link test communication.

REMARK: The column 'Bitrange' is automatically generated from the telegram type and the offset. The column Bitrange shows currently DB_3 instead of DB_0. This isn't a bug in the XML, only a weakness of the formatting. AT THIS POINT, DB_0 WOULD BE CORRECT.

DIRECTION- 1

Offset	Size	Bitrange	Data	ShortCut	Description	Valid Range	Scale	Unit
0	4	DB3.7...DB3.4	RLT MSG-Counter MSB	MC-MSB	Round-trip, covering all RLT_x_1BS messages 4 bit MSB	Enum: _____ :		
4	1	DB3.3	LRN Bit	LRNB	LRN Bit	Enum:		
						0: Teach-in telegram		
						1: Data telegram		
5	2	DB3.2...DB3.1	RLT MSG-Counter LSB	MC-LSB	Round-trip, covering all RLT_x_1BS messages 2 bit LSB	Enum: _____ :		
7	1	DB3.0	MSG-Source	MSGS	Message Source	Enum: _____ 0: RLT Master		

RLT_SlaveTest_1BS

This is the 1BS message sent by the RLT Slave in reply to an RLT_MasterTest_1BS message.

REMARK: The column 'Bitrange' is automatically generated from the telegram type and the offset. The column Bitrange shows currently DB_3 instead of DB_0. This isn't a bug in the XML, only a weakness of the formatting. AT THIS POINT, DB_0 WOULD BE CORRECT.

DIRECTION- 2

Offset	Size	Bitrange	Data	ShortCut	Description	Valid Range	Scale	Unit
0	4	DB3.7...DB3.4	RLT MSG-Counter MSB	MC-MSB	Round-trip, covering all RLT_x_1BS messages 4 bit MSB	Enum: _____ :		
4	1	DB3.3	LRN Bit	LRNB	LRN Bit	Enum:		
						0: Teach-in telegram		
						1: Data telegram		
5	2	DB3.2...DB3.1	RLT MSG-Counter LSB	MC-LSB	Round-trip, covering all RLT_x_1BS messages 2 bit LSB	Enum: _____ :		
7	1	DB3.0	MSG-Source	MSGS	Message Source	Enum: _____ 1: RLT-Slave		

D2: VLD Telegram

D2-00: Room Control Panel (RCP)

The Communication is based on the Smart Ack concept. Some basics related hereto are included in this document for convenience but for details please consult the Smart Ack specification.

A Room Control Panel (RCP) compliant to this EEP offers the following features:

- Multi symbol, multi segment LC display (or equivalent)
- 1 temperature measurement channel, remote configurable
- 1 temperature set point control (e.g. key pad based)
- 1 fan speed control (e.g. key pad based)
- 1 presence control (e.g. key pad based)

Repeater operation shall work in compliance with the Smart Ack specification.

RORG	D2	VLD Telegram
FUNC	00	Room Control Panel (RCP)
TYPE	01	RCP with Temperature Measurement and Display (BI-DIR)

Message type A / ID 01 (First User Action on RCP)

Direction: Sensor -> Gateway

Transaction Response: Message Type B or Type E

Chaining: No

Timing: T1+ = 170ms

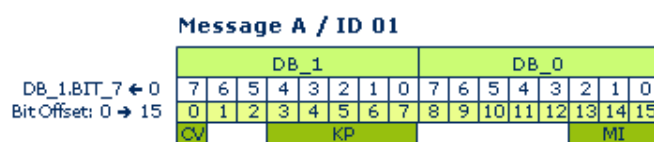

Offset	Size	Data	ShortCut	Description	Valid Range	Scale	Unit	
0	1	ConfigValid	CV		Enum:			
					0: Configuration data not valid (e.g. never received message of type E)			
					1: Configuration data valid			
1	2	Not Used (= 0)						
3	5	User Action	KP		Enum:			
					0: not used			
					1: Presence			
					2: Temperature Set Point "down" or "-"			
					3: not used			
					4: not used			
					5: Temperature Set Point "up" or "+"			
					6: Fan			
					0x07...0x1F: Not Used			
8	5	Not Used (= 0)						

13	3	MsgId	MI	Message Id; 0x01	Enum: 1: Message Id
----	---	-------	----	---------------------	------------------------

Message Type B / ID 02 (Display Content)

Direction: Gateway -> Sensor

Reply to Message Type A

Response: None

Chaining: Up to 2 messages per chain

Timing: T2+ = 300ms

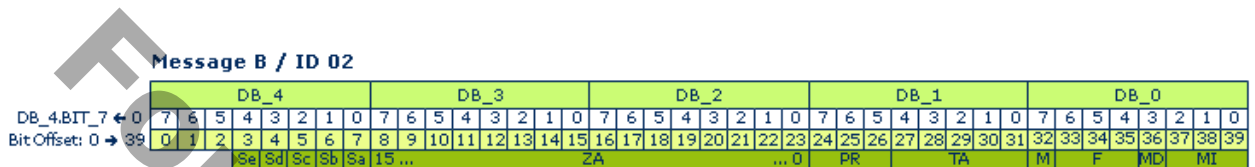

The symbols Sa, Sb, Sc, Sd, Se are optional. One or more of those symbols are available on the display only if the manufacturer of a RCP implements them in a specific design. Thus, they are NOT mandatory for a RCP in order to comply with this EEP.

Offset	Size	Data	ShortCut	Description	Valid Range	Scale	Unit
0	3	Not Used (= 0)					
3	1	User Notification	Se	optional	Enum: 0x00: Off 0x01: On		
4	1	Window	Sd	optional	Enum: 0x00: Closed 0x01: Opened		
5	1	Dew-Point	Sc	optional	Enum: 0x00: Warning 0x01: No warning		
6	1	Cooling	Sb	optional	Enum: 0x00: Off 0x01: On		
7	1	Heating	Sa	optional	Enum: 0x00: Off 0x01: On		
8	16	Figure A Value	ZA	Format according to TA:	Enum: 0x01...0x07: 0 ... 4000 0.01° 0x08...0x0A: Time 0000 ... 2359 0x0B...0x0C: Date 0101 ... 3112 0x0D: 0 ... 9999 lx 0x0E...0x10: 0 ... 10000 0.01% 0x0F: 0 ... 999 ppm		
24	3	Presence	PR		Enum: 0x00: Do not display 0x01: Present 0x02: Not present 0x03: Night time reduction 0x04...0x07: not used		
27	5	Figure A Type	TA		Enum: 0x00: Do not display 0x01: Room Temperature °C 0x02: Room Temperature °F 0x03: Nominal Temperature °C		

					0x04: Nominal Temperature °F
					0x05: Delta Temperature Set Point °C
					0x06: Delta Temperature Set Point °F
					0x07: Delta Temperature Set Point(graphic)
					0x08: Time 00:00 to 23:59 [24h]
					0x09: Time 00:00 to 11:59 [AM]
					0x0A: Time 00:00 to 11:59 [PM]
					0x0B: Date 01.01 to 31.12 [DD.MM]
					0x0C: Date 01.01 to 12.31 [MM.DD]
					0x0D: Illumination (linear) 0 to 9999 lx
					0x0E: Percentage 0 to 100
					0x0F: Parts per Million 0 to 9999 ppm
					0x10: Relative Humidity 0 to 100 %rH
					0x11...0x1F: not used
32	1	Fan manual	M		Enum: 0: Auto 1: Fan maual
33	3	Fan	F		Enum: 0: Do not display 1: Speed Level 0 2: Speed Level 1 3: Speed Level 2 4: Speed Level 3 5...7: not used
36	1	MoreData	MD		Enum: 0: no more data 1: more data will follow after T2+
37	3	MsgId	MI	Message Id;0x02	Enum: 2: Message Id

Message Type C / ID 03 (Repeated User Action on RCP)

Direction: Sensor -> Gateway

Fire and Forget

Response: None

Chaining: No

Timing: may only be sent within 5s from latest receipt of a Message Type B

Message C / ID 03

	DB_3							DB_2							DB_1							DB_0																											
DB_3.BIT_7 ← 0	7	6	5	4	3	2	1	0	7	6	5	4	3	2	1	0	7	6	5	4	3	2	1	0	7	6	5	4	3	2	1	0																	
Bit Offset: 0 → 31	0	1	2	3	4	5	6	7	8	9	10	11	12	13	14	15	16	17	18	19	20	21	22	23	24	25	26	27	28	29	30	31																	
	15 ...							ZA							... 0							PR							TA							F							MI						

Offset	Size	Data	ShortCut	Description	Valid Range	Scale	Unit
0	16	Set Point A Value	ZA	Format according to TA: 0x05 [0.01°]	-1270...+1270	-12.70...+12.70	°
16	3	Presence	PR		Enum: 0x00: no change 0x01: Present 0x02: Not present 0x03: Night time reduction 0x04...0x07: not used		

19	5	Set Point A Type	TA		Enum: 0x00: no change not used 0x01...0x04: 0x05: Temperature Set Point [°] 0x06...0x1F: not used
24	1	Not Used (= 0)			
25	3	Fan	F		Enum: 0: no change 1: Speed Level 0 2: Speed Level 1 3: Speed Level 2 4: Speed Level 3 5: Speed Level Auto 6...7: not used
28	1	Not Used (= 0)			
29	3	MsgId	MI	Message Id; 0x03	Enum: 3: Message Id

Message Type D / ID 04 (Measurement Result)

Direction: Sensor -> Gateway
 Fire and Forget
 Response: None
 Chaining: No
 Timing: None

Message D / ID 04

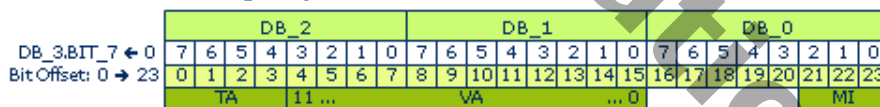

Offset	Size	Data	ShortCut	Description	Valid Range	Scale	Unit
0	4	Channel A Type	TA		Enum: 0x00: Temperature [°C] 0x01...0x0E: not used 0x0F: Measurement result not valid		
4	12	Channel A Value	VA	Format according to TA:	0...4000	0...40.00	°
16	5	Not Used (= 0)					
21	3	MsgId	MI	Message Id; 0x04	Enum: 4: Message Id		

Message Type E / ID 05 (Sensor Configuration)

Direction: Gateway -> Sensor
 Reply to Message Type A
 Response: None
 Chaining: Up to 2 messages per chain
 Timing: T2+ = 300ms

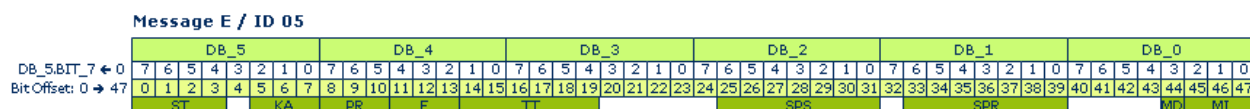

Offset	Size	Data	ShortCut	Description	Valid Range	Scale	Unit	
0	4	Significant Temperature Difference	ST	Difference between two subsequent temperature measurements to trigger a Message Type D [0.2°]	0x0...0xF	0.0...3.0	°	
4	1	Not Used (= 0)						
5	3	Keep Alive Timing	KA	Number of measurements between two subsequent "Keep Alive messages"	Enum: 0: Transmission of measurement result with each Temperature measurement 0x1...0x7: measurement *10			
8	3		PR	Number of Presence Levels available to user	Enum: 0: Presence disabled 0x1...0x7: Presence available			
11	3	Fan	F	Number of Fan Speed Levels available to user:	Enum: 0: Fan Speed disabled 0x1...0x7: Fan Speeds			
14	6	Temperature Measurement Timing	TT	Time between two subsequent Temperature measurements	Enum: 0x01...0x3C: measurement disabled		s	
20	5	Not Used (= 0)						
25	7	Set PointSteps	SPS	Number of Set Point Steps:	Enum: 0: Set Point disabled 0x01...0x7F: Set point			
32	1	Not Used (= 0)						
33	7	Set Point Range Limit	SPR	Limit of Set Point Range, absolute value:	Enum: 0: Set Point disabled 0x01...0x7F: Set point		°	
40	4	Not Used (= 0)						
44	1	MoreData	MD		Enum: 0: no more data 1: more data will follow after 300ms			
45	3	MsgId	MI	Message Id; 0x05	Enum: 5: Message Id			

3) Appendix

3.1) RPS Teach-in

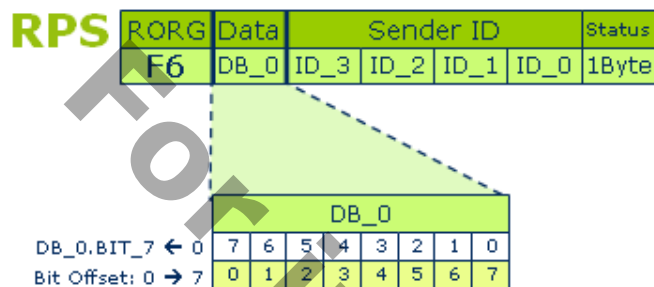

The RPS telegram can only send data and has no special telegram modification to teach-in the device. Therefore, the teach-in procedure takes place manually on the actuator/controller through a normal data telegram. The EEP profile must be manually supplied to the controller per sender ID.

In learn mode, the receiving actuator reduces the input sensitivity in order to fade out weakly received data telegrams. This helps avoid inadvertently teaching-in sensors.

3.2) 1BS Teach-in

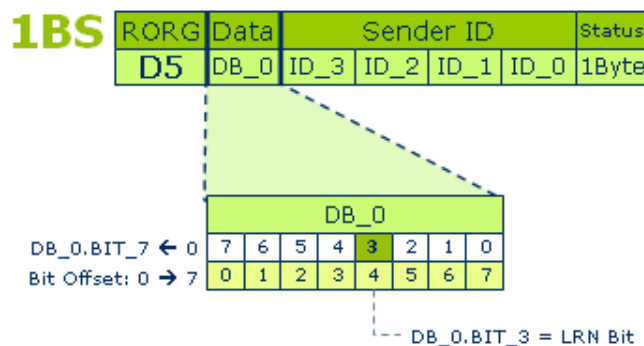

The 1BS telegram has its own teach-in telegram, which can signal the teach-in command through the DB_0.BIT_3 data bit.

Offset	Size	Bitrange	Data	Valid Range	Scale	Unit
4	1	DB0.3	LRN Bit	Enum:		
				0: Teach-in telegram		
				1: Data telegram		

Here, an EEP profile must also be manually allocated per sender ID.

3.3) 4BS Teach-in

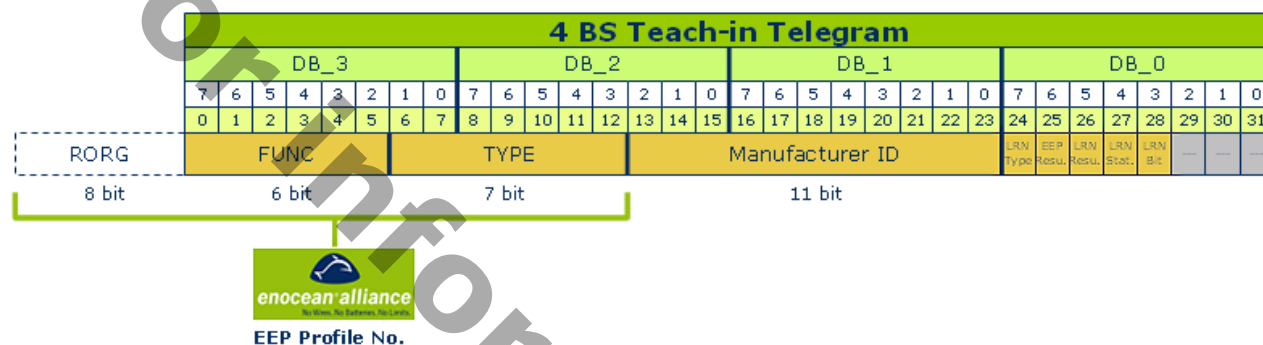

The 4BS telegram also has its own teach-in telegram, however with more teach-in variations:

Variation 1

The profile-less unidirectional teach-in procedure functions according to the same principle as the 1BS telegram: if the data bit is DB_0.BIT_3 = 0, then a teach-in telegram is sent. This includes the 'LRN TYPE' DB_0.BIT_7 = 0 data bit. Then no EEP profile identifier and no manufacturer ID are transferred.

Offset	Size	Bitrange	Data	Valid Range	Scale	Unit
24	1	DB0.7	LRN Type	Enum:		
				0: telegram without EEP and Manufacturer ID		
28	1	DB0.3	LRN Bit	Enum:		
				0: Teach-in telegram		
				1: Data telegram		

Variation 2

For the unidirectional profile teach-in procedure, it is preferred in opposite to variation 1), as the teach-in telegram contains both the complete EEP number and the manufacturer ID. The device is therefore clearly identifiable as ready-to-use and can be securely executed in a complex system environment or by foreign systems. In this case, the 'LRN TYPE' data bit is DB_0.BIT_7 = 1.

Offset	Size	Bitrange	Data	Valid Range	Scale	Unit
24	1	DB0.7	LRN Type	Enum:		
				1: telegram with EEP number and Manufacturer ID		

28	1	DB0.3	LRN Bit	Enum:
				0: Teach-in telegram
				1: Data telegram

Variation 3

During the bidirectional teach-in procedure, further bits are required from the DB_0, in order to develop the mutual teach-in between two communication partners. For this, the procedure is made up of 2 teach-in telegrams, which are exchanged on both sides. The following UML diagram is used to illustrate this:

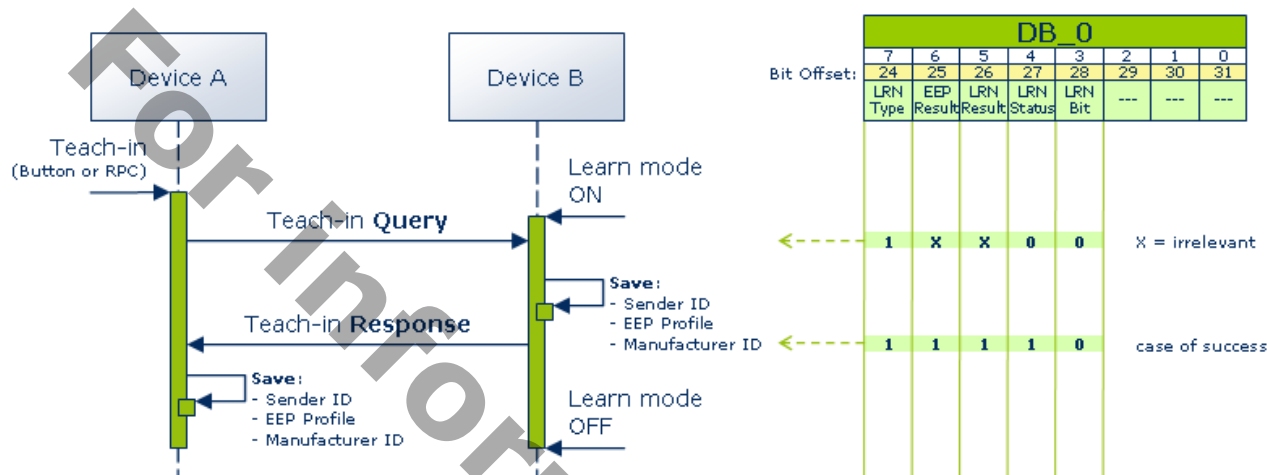

Offset	Size	Bitrange	Data	Valid Range	Scale	Unit
24	1	DB0.7	LRN Type	Enum:		
				0: telegram without EEP and Manufacturer ID		
				1: telegram with EEP number and Manufacturer ID		
25	1	DB0.6	EEP Result	Enum:		
				0: EEP not supported		
				1: EEP supported		
26	1	DB0.5	LRN Result	Enum:		
				0: Sender ID deleted/not stored		
				1: Sender ID stored		
27	1	DB0.4	LRN Status	Enum:		
				0: Query		
				1: Response		
28	1	DB0.3	LRN Bit	Enum:		
				0: Teach-in telegram		
				1: Data telegram		

3.4) Smart Ack Teach-in (without repeater)

Under Smart Ack (SA), the teach-in procedure is more complex as, alongside the SA client and SA controller, a Postmaster must also be established to prepare a mailbox for each taught-in SA client. The Postmaster is normally found in the controller. If a repeater is installed, then a postmaster is set up there.

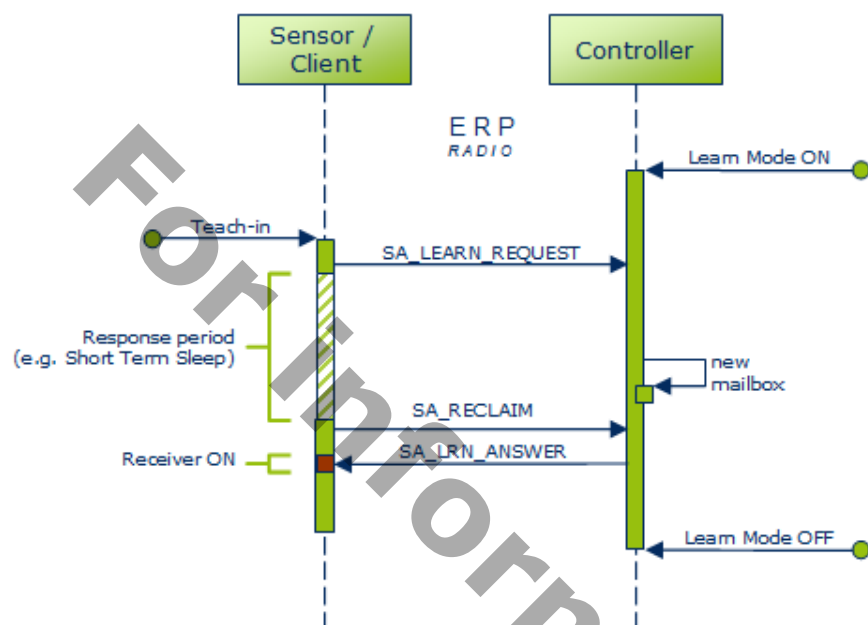

After the learn mode is activated on the controller, the teach-in procedure can be started on the client. The client sends an SA_LEARN_REQUEST telegram:

RORG	Req.	Manuf.ID	EEP (3 byte)			RSSI	Repeater ID					Sender ID				Status	CHCK
C6	5 bit	11 bit	RORG	FUNC	TYPE	dBm	ID_3	ID_2	ID_1	ID_0	ID_3	ID_2	ID_1	ID_0	1 Byte	1 Byte	

Request Code

Data	Value	Description
Request Code	0b11111	Default value – send by sensor
Manufacturer ID	0bnnnnnnnnnn	Corresponding to the teach-in sensor
EEP No.	0xnnnnnn	RORG, FUNC, TYPE
RSSI	0x00	0 = Without repeater
Repeater ID	0x00000000	0 = Without repeater
Sender ID	0xnnnnnnnn	Chip ID of sensor for teach-in
Status	0x0F	0F = no repeating permitted
CHCK	0xnn	Checksum

During the 'response period' in the SA client, which is always 550 ms during the teach-in, the controller creates a new mailbox in its postmaster and leaves its first message there with an OK receipt. This entry is requested from the postmaster by the SA client with an SA_RECLAIM 'Learn' telegram:

Choice	RCLM_ID	Sender ID				Status
A7		ID_3	ID_2	ID_1	ID_0	1Byte

----- Mailbox Index (only Data Reclaim)
 ----- bit 7=0 Learn Reclaim / 1 Data Reclaim

Data	Value	Description
Message Index	0b0	Bit 7: 0 = Learn Reclaim
Sender ID	0xn timer	Chip ID of sensor for teach-in
Status	0x0F	0F = no repeating desired
CHCK	0xnn	Checksum

The final telegram sent to the SA client, SA_LRN_ANSWER, contains the 'Learn Acknowledge' message from the mailbox that the teach-in procedure has been carried out successfully:

Smart Ack Learn Answer (Learn Acknowledge)

RORG	RORG-EN	Index	Response time	Ack-C	Mailbox	not used			Postmaster ID				Controller ID				Status	CHCK	
0	1	2	3	4	5	6	7	8	9	10	11	12	13	14	15	16	17	18	19
A6	C7	02					-	-	-	ID_3	ID_2	ID_1	ID_0	ID_3	ID_2	ID_1	ID_0		

Data	Value	Description
RORG	0xA6	A6 = ADR Telegram
RORG-EN	0xC7	RORG encapsulated / C7 = SA_LRN_ANSWER
Index	0x02	Message Index; 02 = Learn Acknowledge
Response time	0xn timer	Response time for Smart Ack Client in ms in which the controller can prepare the data and send it to the postmaster (max. value 550 ms = 0x0226)
Acknowledge code	0x00	First Learn In successful
Mailbox index	0xnn	Index no. of the assigned mailbox
Postmaster ID	0xn timer	Device ID of the Post master candidate
Controller ID	0xn timer	Device ID of the assigned controller
Status	0x0F	0F = no repeating permitted
CHCK	0xnn	Checksum

3.5) Smart Ack Teach-in (with repeater)

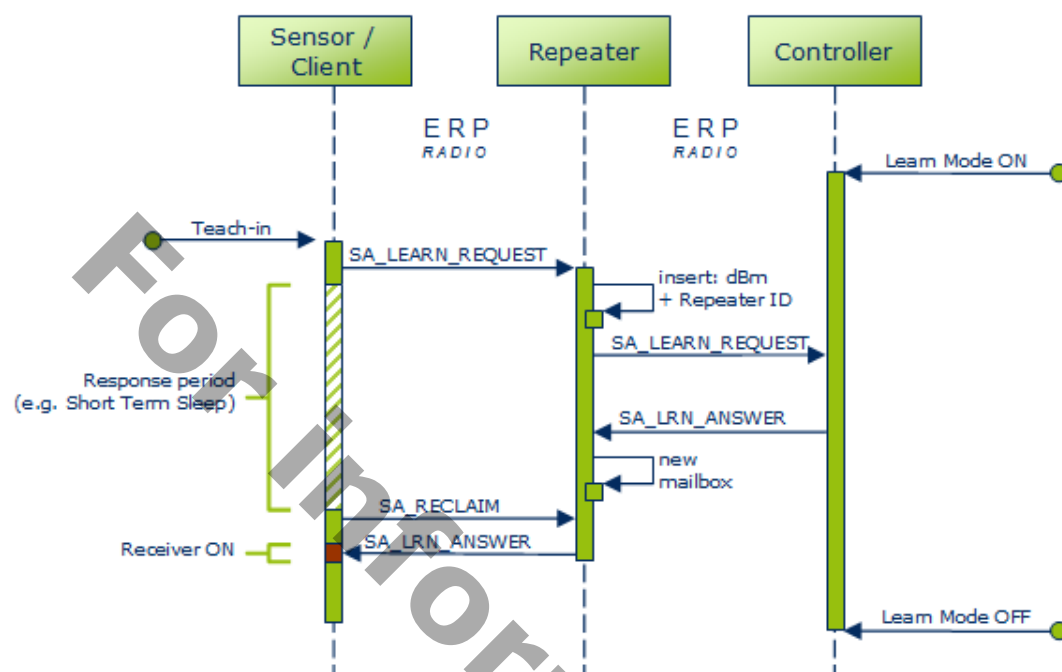

If a repeater comes into operation, the SA_LEARN_REQUEST telegram sent by the SA client (with an EEP No., Manufacturer ID, Sender ID) is completed on the repeater with the RSSI value (in dBm) and the Repeater ID, and sent to the controller.

RORG	Req.	Manuf.ID	EEP (3 byte)			RSSI	Repeater ID				Sender ID				Status	CHCK
C6	5 bit	11 bit	RORG	FUNC	TYPE	dBm	ID_3	ID_2	ID_1	ID_0	ID_3	ID_2	ID_1	ID_0	1 Byte	1 Byte

Request Code

Data	Value	Description
Request Code	0b11111	Default value – send by sensor
Manufacturer ID	0bnnnnnnnnnn	Corresponding to the teach-in sensor
EEP No.	0xnnnnnn	RORG, FUNC, TYPE
RSSI	0xnn	Value added from repeater
Repeater ID	0xnnnnnnnn	Device ID repeater
Sender ID	0xnnnnnnnn	Chip ID of sensor for teach-in
Status	0x0F	0F = no repeating permitted
CHCK	0xnn	Checksum

From the reception strength of the RSSI, the controller can recognise which repeater is best for the task of postmaster. In the meantime, the SA client will be in its 'response period'. The sent addressed telegram **SA_LRN_ANSWER** with the message 'Learn Reply' by the controller to the repeater ensures that the postmaster is activated and a mailbox is created.

RORG	Req.	Manuf.ID	EEP (3 byte)			RSSI	Repeater ID				Sender ID				Status	CHCK
C6	5 bit	11 bit	RORG	FUNC	TYPE	dBm	ID_3	ID_2	ID_1	ID_0	ID_3	ID_2	ID_1	ID_0	1 Byte	1 Byte

Request Code

Data	Value	Description
RORG	0xA6	A6 = ADR Telegram
RORG-EN	0xC7	RORG encapsulated / C7 = SA_LRN_ANSWER
Index	0x01	Message Index; 01 = Learn Reply
Response time	0xnnnn	Response time for Smart Ack Client in ms in which the controller can prepare the data and send it to the postmaster (max. value 550 ms = 0x0226)
Acknowledge code	0x00	First Learn In successful
Sender ID	0xnnnnnnnn	Chip ID of sensor to be teach-in
Postmaster ID	0xnnnnnnnn	Device ID of the Post master candidate
Controller ID	0xnnnnnnnn	Device ID of the assigned controller
Status	0x0F	0F = no repeating permitted
CHCK	0xnn	Checksum

Also, a mailbox is created for the SA client, where an initial entry with an OK message is left. This information is requested by the SA client from the repeater's postmaster with the SA_RECLAIM 'Learn' telegram.

Choice	RCLM_ID	Sender ID				Status
A7		ID_3	ID_2	ID_1	ID_0	1Byte

Mailbox Index (only Data Reclaim)
bit 7=0 Learn Reclaim / 1 Data Reclaim

Data	Value	Description
Message Index	0b0	Bit 7: 0 = Learn Reclaim
Sender ID	0xnnnnnnnn	Chip ID of sensor for teach-in
Status	0x0F	0F = no repeating desired
CHCK	0xnn	Checksum

The final telegram sent to the SA client, SA_LRN_ANSWER, contains the 'Learn Acknowledge' message from the mailbox that the teach-in procedure has been carried out successfully:

Smart Ack Learn Answer (Learn Acknowledge)

RORG	RORG-EN	Index	Response time	Ack C.	Mailbox	not used			Postmaster ID				Controller ID				Status	CHCK	
0	1	2	3	4	5	6	7	8	9	10	11	12	13	14	15	16	17	18	19
A6	C7	02					-	-	-	ID_3	ID_2	ID_1	ID_0	ID_3	ID_2	ID_1	ID_0		

Data	Value	Description
RORG	0xA6	A6 = ADR Telegram
RORG-EN	0xC7	RORG encapsulated / C7 = SA_LRN_ANSWER
Index	0x02	Message Index; 02 = Learn Acknowledge
Response time	0xnnnn	Response time for Smart Ack Client in ms in which the controller can prepare the data and send it to the postmaster (max. value 550 ms = 0x0226)
Acknowledge code	0x00	First Learn In successful
Mailbox index	0xnn	Index no. of the assigned mailbox
Postmaster ID	0xnnnnnnnn	Device ID of the Post master candidate
Controller ID	0xnnnnnnnn	Device ID of the assigned controller

Status	0x0F	0F = no repeating permitted
CHCK	0xnn	Checksum

For information only

3.6) XML + DOC Maintenance process

3.6.1) General

The maintenance process is described separately in the document: EEP2x_Maintenance_Process.pdf.

3.6.2) XML file

With EEP2.1, a new type of documentation is introduced, which can also display logical structures next to the described contents. These can be adapted by developers into their programming environment.

XML is fully compatible with applications like C# or JAVA, and it can be combined with any application which is capable of processing XML irrespective of the platform it is being used on. If the application can work alongside XML, then XML can work on any platform and has no boundaries. It is also vendor independent and system independent.

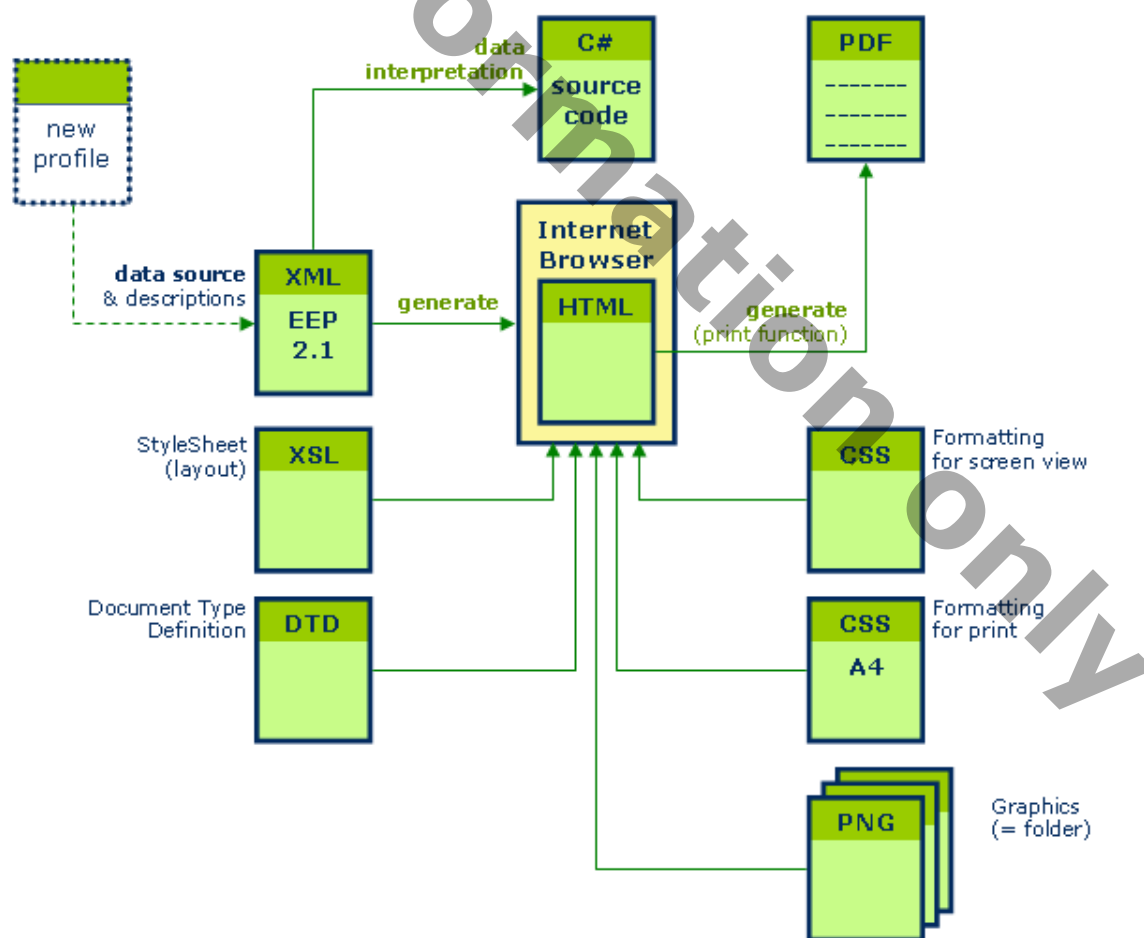

Only the XML data is edited and released in defined time intervals as a total release under a new version. A styles sheet file (XSL) and formatting specifications (CSS) ensure that an attractive HTML representation is possible in an internet browser. The author of the new version also creates a final PDF file.

This method ensures that the document view, as well as the software environment, remain synchronized. Errors are strongly reduced and data maintenance is optimized.

3.7) Smart Ack: functional principle (without repeater)

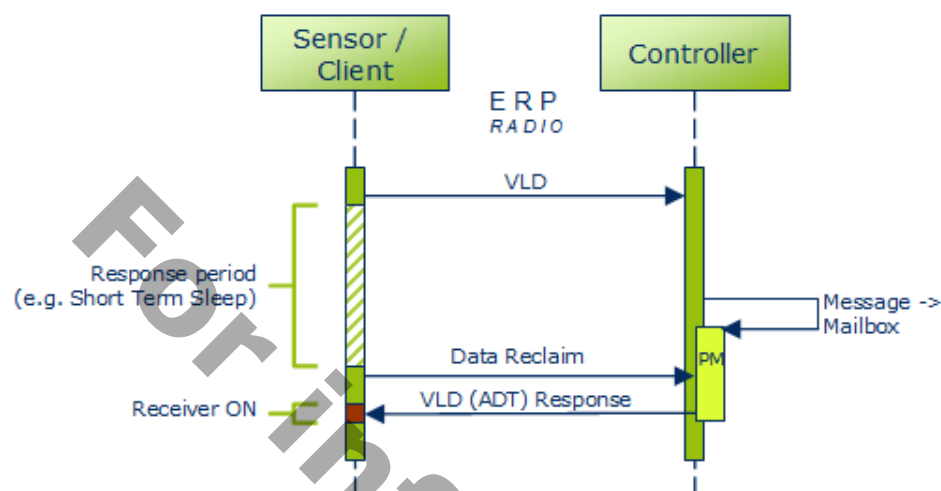

Smart Ack is a bidirectional communication protocol between a self-powered device and a line-powered controller. Data transmission in both directions is controlled by the sensor/client, as the limited energy requires an exact synchronization of the sent and the received messages. This pre-defined time interval allows a very short activation of the energy-intensive receiver electronics on the client.

If the teach-in procedure has already taken place as in Chapter 'Smart Ack Teach-in procedure' and the two devices already 'know each other', communication always takes place as following under Smart Ack:

The client sends its message over a VLD telegram to the controller (Manufacturer ID = optional).

VLD

RORG	Manufacturer ID	Variable data	Sender ID				Status	CRC8
D2	1,5 byte	1 ... 12,5 bytes	ID_3	ID_2	ID_1	ID_0	1 byte	1 byte

Finally, the message is processed in the controller, or forwarded to an external micro-controller over the serial interface for each use case. During the intervening period, the client is in the 'response period', which is frequently connected to an energy saving measure (like 'Short Term Sleep'). The length of this time period is agreed during the teach-in procedure between the devices as 'response time'. The feedback defined for the client is deposited in the mailbox of the postmaster (PM). When the client is active again, it requests this message containing the Smart Ack telegram DATA_RECLAIM from the responsible postmaster.

RORG	Sender ID				Status	CHCK
A7	ID_3	ID_2	ID_1	ID_0	1Byte	1 Byte

bit 0 ... 6: Mailbox Index
bit 7: 1 = Message index 'Data Reclaim'

Finally, the receiver part of the client is activated and the message sent by the postmaster is accepted. In this case the

VLD telegram is sent encapsulated as ADT telegram (= addressed).

ADT / VLD

RORG	RORG-EN	Manufacturer ID	Variable data	Destination ID				Sender ID				Status	CRC8
A6	D2	1,5 byte	1 ... 7,5 bytes	ID_3	ID_2	ID_1	ID_0	ID_3	ID_2	ID_1	ID_0	1 byte	1 byte

3.8) Smart Ack: functional principle (with repeater)

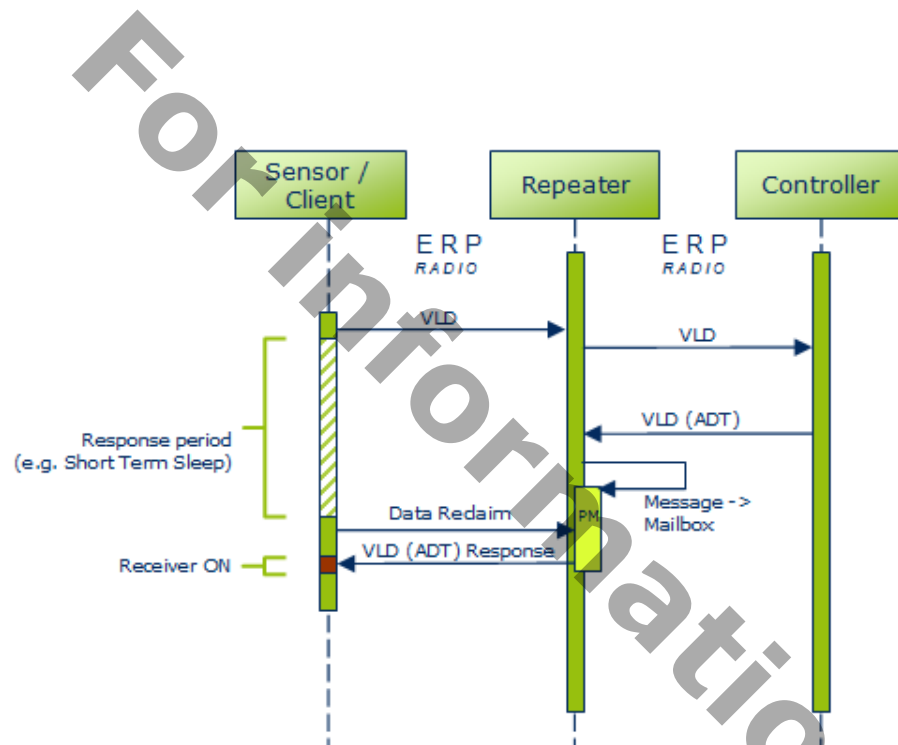

If a repeater is used, it takes over the task of the postmaster after the teach-in procedure. Hence, the client cannot view under operating conditions whether it is communicating directly with a controller or with a repeater.

The VLD telegram of the client is forwarded by the repeater 1:1 in the direction of the controller. The feedback is transferred in the form of an addressed telegram (containing Repeater ID) to the postmaster of the repeater and stored in the mailbox.

The client then turns to the repeater with its 'Data Reclaim', instead of turning to the controller, and requests the response message from the postmaster.

3.9) Remote Management / RPC

Remote Management allows EnOcean devices to be configured and maintained over the air or via a serial interface. For instance sensor or switch IDs can be stored or deleted from already installed actuators or gateways that are hard to access. The remote management library can be used for Dolphin-based products and TCM 200C/220C modules.

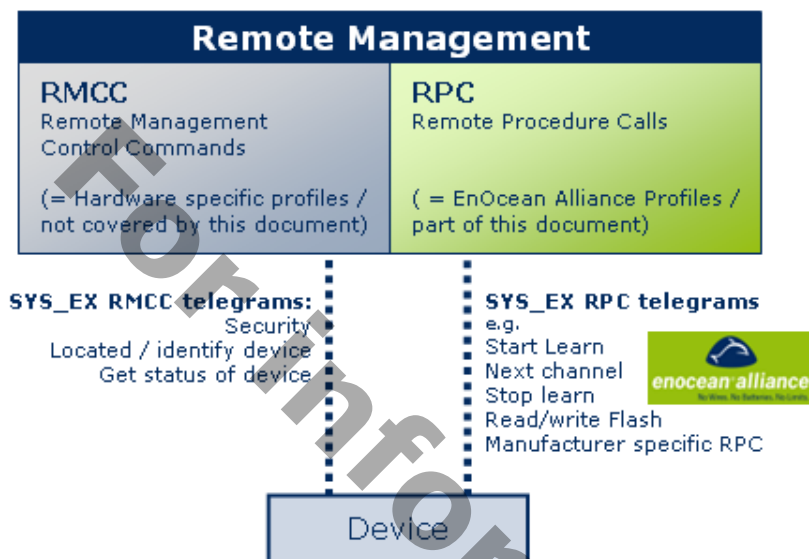

Remote management is divided into two function groups:

RMCCs are mandatory features; they are permanently defined and they have overlapping tasks. They cannot be modified devicespecifically and are therefore, not an integral part of this description.

RPCs cover optional and manufacturer-specific features, and they have a flexible number of functionalities that can be used for numerous devices. If new device properties are mapped, RPCs can be extended correspondingly. To keep the RPCs interoperable, it is in the interest of the EnOcean Alliance to standardize these procedures.

The RPCs available today with their SYS_EX structures do not have any data-technical commonalities with EEP, but are to be handled the same way in future within the framework of coordination measures.

Structure of SYS_EX for RPC

SYS_EX telegrams for RPCs are generally encapsulated in an ADT telegram (RORG = A6) and are sent addressed as such.

ADT / SYS_EX / RPC

RORG	RORG-EN	SYS-EX data	Destination ID				Sender ID				Status	CRC8
A6	C5	x bytes	ID_3	ID_2	ID_1	ID_0	ID_3	ID_2	ID_1	ID_0	1 byte	1 byte

In the following section the SYS_EX data is described in detail. Note that Remote Management RPC commands are composed of several telegrams. That means SYS_EX data is than merged in one data block. The next section describes this datablock in detail. Make sure to read the Remote Management specification for more details.

Type	RPC - Remote learn
Manufacturerid	0x7FF
Datalength	0x04

Broadcast	YES
Addressable	YES
Answer	NO

Offset	Size	Data	Description	Valid Range	Scale	Unit
0	24	EEP (ORG-FUNC-TYPE)	Determines the device type to learn in, all other devices learn telegrams are ignored. To ignore EEPROM control the mask bits has to be set to 0)	
24	8	Flag	learn flag, determines different behaviour of the learn procedure	Enum:		
				0x00: RESERVED		
				0x01: Start learn		
				0x02: Next channel		
				0x03: Stop learn		
				0x04: SmartACK - Start simple learn mode		
				0x05: SmartACK - Start advanced learn mode		
				0x06: SmartACK - Stop learn		

Type	RPC - Remote flash write
Manufacturerid	0x7FF
Datalength	0x04 + N
Broadcast	YES
Addressable	YES
Answer	NO

Using this command the flash of a device can be written.

Offset	Size	Data	Description
0	16	Flash Memory Address	Destination where the data should be stored
16	16	Number of Bytes	Number of bytes to be transferred and written to the flash
32	N*8	Data	data to be transferred and written to the flash

Type	RPC - Remote flash read
Manufacturerid	0x7FF
Datalength	0x04
Broadcast	NO
Addressable	YES
Answer	YES

Using this command the flash can be read from the application. The data requested data area transmitted in RPC telegrams.

Offset	Size	Data	Description
16	16	Number of Bytes	Number of bytes to be transferred and written to the flash

Type	RPC - Remote flash read answer
Manufacturerid	0x7FF

Datalength	N
Broadcast	NO
Addressable	YES
Answer	NO

Offset	Size	Data	Description
0	N*8	Data	data read from flash

Type	RPC - SmartACK read settings
Manufacturerid	0x7FF
Datalength	1
Broadcast	NO
Addressable	YES
Answer	YES

Using this command the SmartACK settings and learn tables can be read from the device. The Setting type filled determines what type of data is requested. The data requested data area transmitted in RPC telegrams.

Offset	Size	Data	Description	Valid Range	Scale	Unit
0	8	>Setting type	type of settings to read	Enum: RESERVED 0x00: Mailbox settings 0x01: Learned sensor - read the ID table of sensors in the 0x02: Controller		

Type	RPC - SmartACK read settings - Mailbox settings answer
Manufacturerid	0x7FF
Datalength	4
Broadcast	NO
Addressable	YES
Answer	NO

Offset	Size	Data	Description
0	16	SmartACK flash address	Address where the SmartACK settings are stored
16	16	SmartACK mailbox count	number of mailboxes stored in flash

Type	RPC - SmartACK read settings - Learned sensor answer
Manufacturerid	0x7FF
Datalength	N*9
Broadcast	NO
Addressable	YES
Answer	NO

N - is the number of entries: SensorID, ControllerID, LearnCount

Offset	Size	Data
N*0	32	SensorID
N*32	32	ControllerID
N*64	8	Learned Count

Type	RPC - SmartACK write settings
Manufacturerid	0x7FF
Datalength	10
Broadcast	NO
Addressable	YES
Answer	YES

Using this command different type of data can be transmitted to the SmartACK devices. This command is useful when the SmartACK device has to be configured remotely. The structure of the data transmitted is depends on the Operation Type field.

Operation Type = 0x01: Add mailbox (only controller)

Offset	Size	Data	Value	Description
0	8	Operation Type	0x01	Add mailbox (only controller)
8	8	Mailbox Index		
16	32	SensorID		
48	32	PostmasterID		

Operation Type = 0x02: Delete mailbox

Offset	Size	Data	Value	Description
0	8	Operation Type	0x02	Delete mailbox
8	8	Mailbox Index		
16	64	Not Used (= 0)		

Operation Type = 0x03: LearnIn - only controller

Offset	Size	Data	Value	Description
0	8	Operation Type	0x03	LearnIn - only controller
8	8	Learn Count		
16	32	SensorID		
48	32	ControllerID		

Operation Type = 0x04: LearnOut - only controller

Offset	Size	Data	Value	Description
0	8	Operation Type	0x04	LearnOut - only controller
8	8	Learn Count		
16	32	SensorID		
48	32	ControllerID		

3.10) Existing 'bidirectional' profile structures

At present, 3 different communication variants having the existing XML structure can be mapped, which approximate the principles of a bi-directional data transfer. The teach-in procedure required for this is described in the same chapter.

The original terminology 'transmit mode / receive mode' was not taken over, as no unique assignment to device type and hence to transmission direction can be derived there from. A neutral number (Direction 1 / 2) or the state of a bit should allow the required free space to the individual application.

Variant 1:

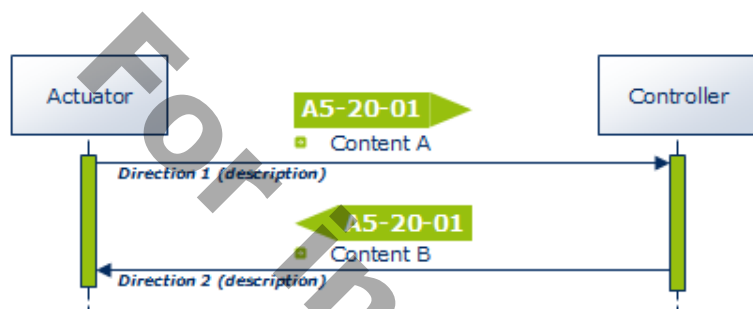

In Variant 1, there is no data-technical differentiation option in the 4BS telegram between Direction 1 and Direction 2, but only a documentation-related direction specification. No transmission direction can be detected if the telegrams are monitored on the radio stretch.

Variant 2:



In Variant 2, 3 bits are provided in the 4BS telegram, which allow up to 8 different data interpretations of the same EEP Profile No. through bit combination. 1 bit is used for direction (with the instruction text 'message source') and 2 bits for the Message ID.

Variant 3:

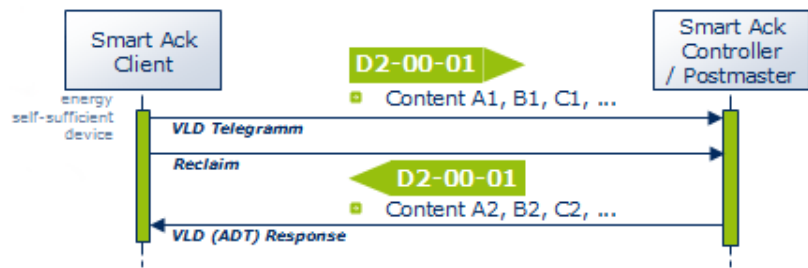

In Variant 3, the Smart Ack technology normally offers multiple use options of bidirectional data transmission. Smart Ack clients can therefore be energy self-sufficient devices. The used VLD telegrams allow a payload of up to 14 bytes (12.5 bytes with Manufacturer ID). Contents can thus be structured more individually.

For information only

3.11) MSC telegram - Manufacturer Specific Communication

Communication over MSC telegrams can always be used when bigger data volumes are to be transmitted, and at the same time, a closed system structure is to be created. This can be the case if e.g., the controller system backbone is expanded to include radio components, or if safety-related controls require proprietary data structures.

Such communication must not affect any interoperable EEP-based communication and should be identifiable as MSC by any Dolphin-based hardware.

Interoperability Conditions:

A device using MSC in addition to other EEPs may be marked with the EnOcean ingredient logo, as long as it complies with the rules defined by the EnOcean alliance for such markings. A device using MSC may be marked with the EnOcean ingredient logo even though the manufacturer does not disclose any or all information regarding the MSC payload. However, all other functionality of such a device shall comply with the latest EEP specification and such a device shall support at least one additional EEP. The manufacturer must clearly state which EEP(s) the device complies with. To safeguard interoperability, if there is sufficient justified doubt within the EnOcean Alliance TWG, a specific unit using MSC can be assessed by the TWG and if found to breach the interoperability intentions, the TWG may then decide (majority vote) to adapt the rules for the usage of the interoperability logo.

The MSC telegram has the same structure as a VLD telegram. The only difference is that the RORG Number is different and the payload specification is missing.

MSC

RORG	Manufacturer ID	Variable data	Sender ID				Status	CRC8
D1	1,5 byte	1 .. 12,5 bytes	ID_3	ID_2	ID_1	ID_0	1 byte	1 byte

The following points are to be noted:

1. The usage of the Multi User Manufacturer ID (0x7FF) shall not be allowed.
2. Each user may send MSC telegrams under his own Manufacturer ID. The Manufacturer ID should not be left out.

3.12) Use Cases for profile 2D-00-01 (self powered RCP for 2way operation)

Use Case: Temperature Measurement

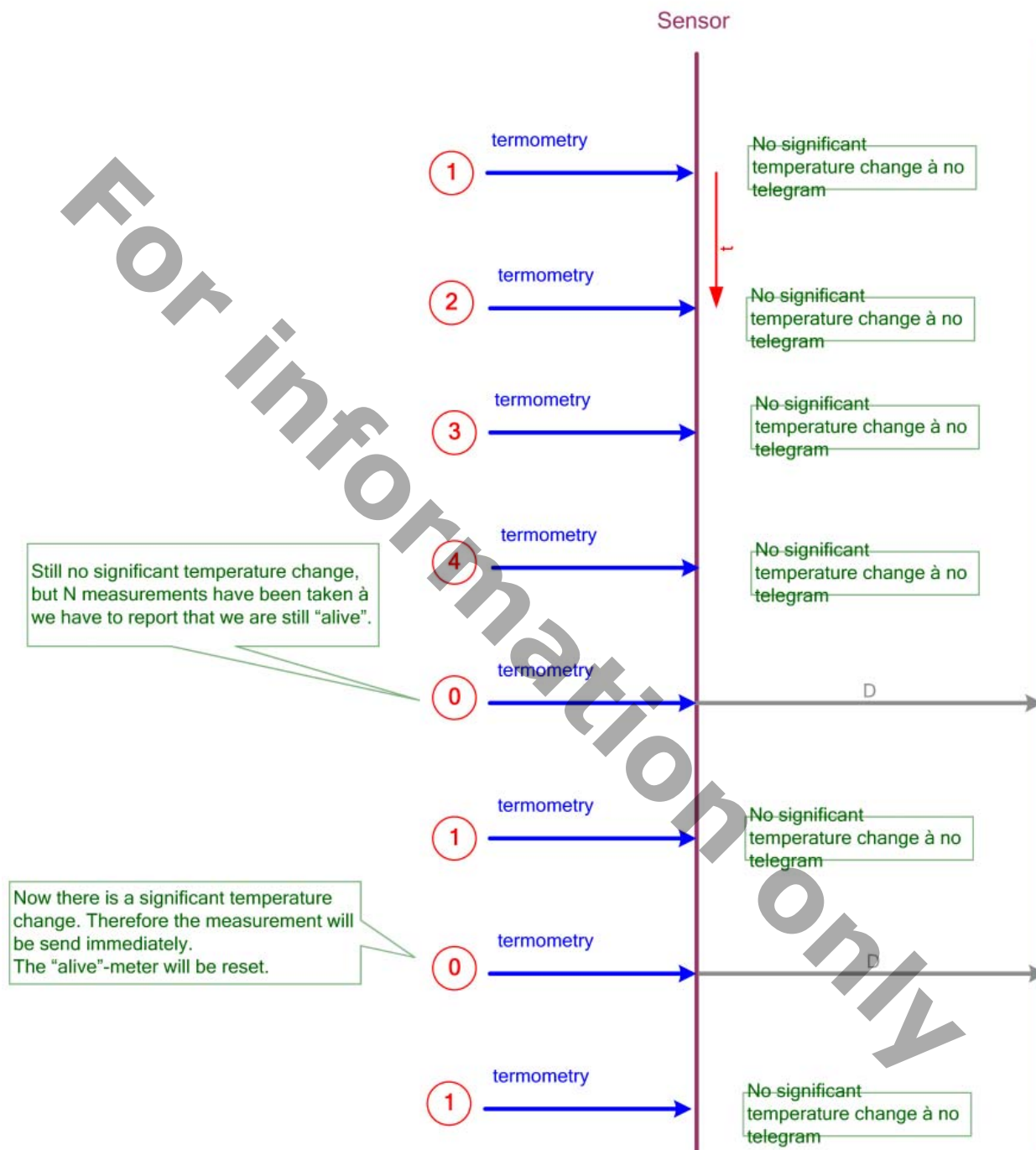

REMARK:

Temperature measurement may be configured by the Gateway, see chapter "Message Type E – RCP Configuration".

Use Case: User Interaction

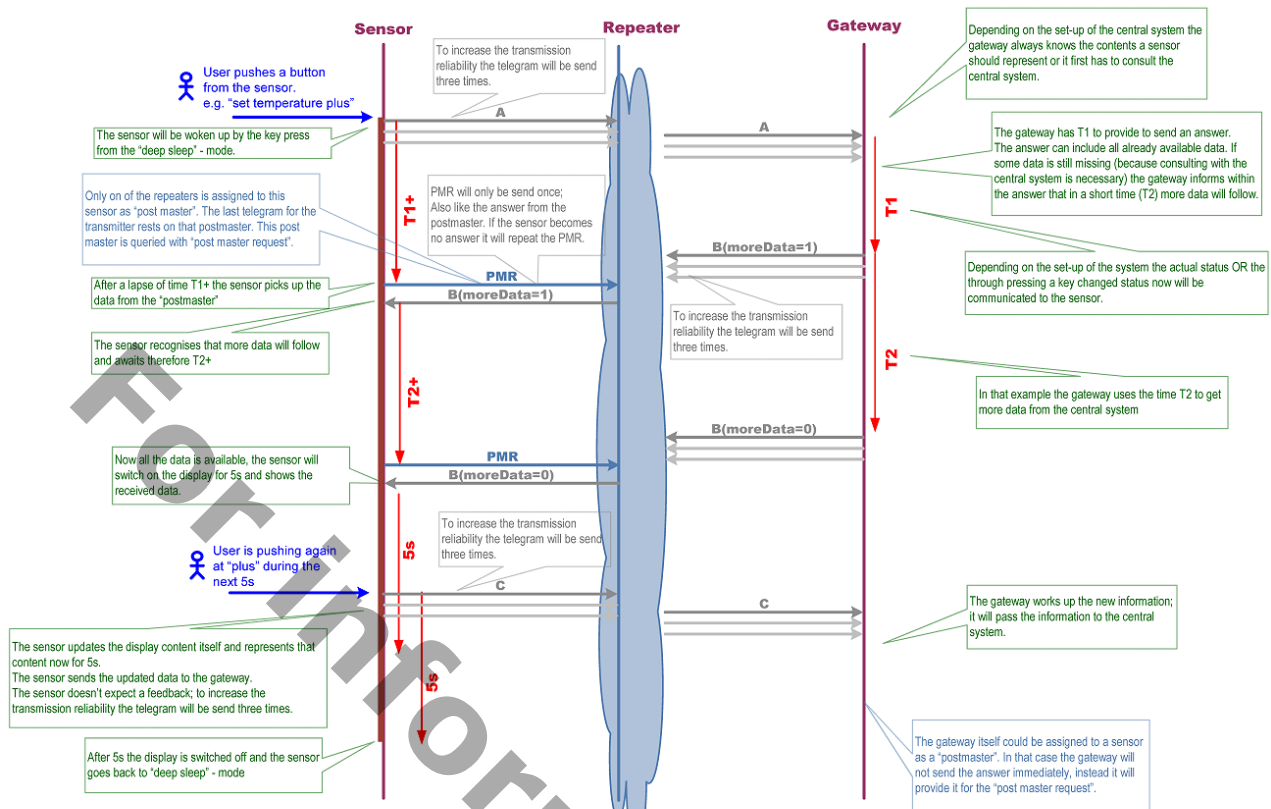

For information only

Use Case: User Interaction including transfer of configuration data

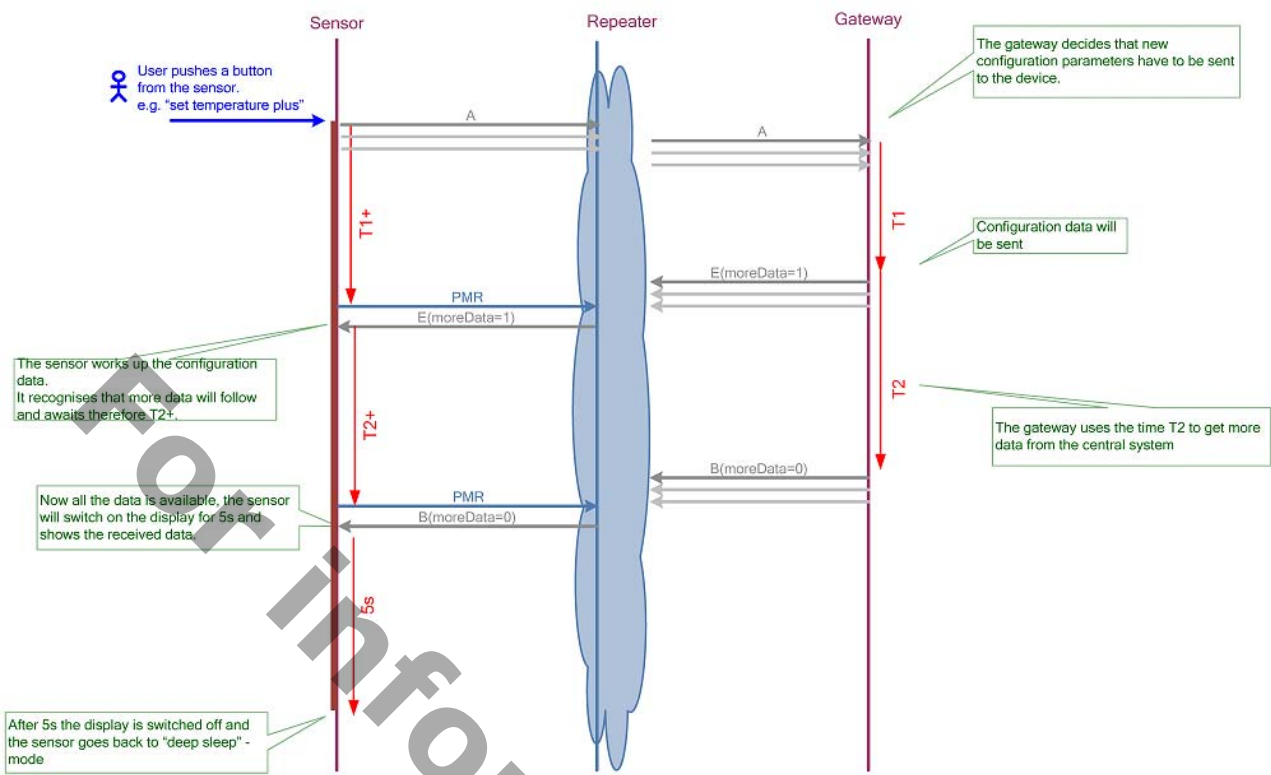

Information only

3.13) Manufacturer ID's

Guidelines:

Upon request, alliance members with membership level promoter or participant will be assigned a unique Manufacturer ID by the EnOcean Alliance. Once assigned, usage of this unique Manufacturer ID is mandatory. For those not holding a unique Manufacturer ID usage of the Multi User Manufacturer ID is mandatory.

Termination of the EnOcean Alliance membership at the membership levels stated above shall also terminate the right of programming an assigned unique Manufacturer ID into devices manufactured after the termination date. However, the unique Manufacturer ID will remain listed in this specification and it will not be assigned to any other alliance member within a time frame of at least 10 years after termination.

The Manufacturer ID applicable to an EnOcean device shall be programmed into any new unit sold to the market after December 2009.

All information and processes required for programming a Manufacturer ID into EnOcean enabled radio modules or chip sets are under the responsibility of the respective Suppliers. Such details are out of scope of the EnOcean Alliance.

Manufacturer	ID
Peha	0x001
Thermokon	0x002
Servodan	0x003
EchoFlex Solutions	0x004
Omnio AG	0x005
Hardmeier electronics	0x006
Regulvar Inc	0x007
Ad Hoc Electronics	0x008
Distech Controls	0x009
Kieback + Peter	0x00A
EnOcean GmbH	0x00B
Probare	0x00C
Eltako	0x00D
Leviton	0x00E
Honeywell	0x00F
Spartan Peripheral Devices	0x010
Siemens	0x011
T-Mac	0x012
Reliable Controls Corporation	0x013
Elsner Elektronik GmbH	0x014
Diehl Controls	0x015
BSC Computer	0x016
S+S Regeltechnik GmbH	0x017
Masco Corporation	0x018
Intesis Software SL	0x019
Res.	0x01A
Lutuo Technology	0x01B
CAN2GO	0x01C
Multi user Manufacturer ID	0x7FF

3.14) Revision

Rev.	Date	Editor	Major Changes
0.10		GT	Initial EnOcean Alliance Version created, based on the EnOcean GmbH document "Standardization EnOcean Communication Profiles_v1.04"
0.90		TR	EEP for ORG = 0x05 added EEP for ORG = 0x06 added Headlines and Text formatted
0.91		TR	FUNC = 11 "Controller Status" added Proposals added: EEP 07-11-01 "Lightning Controller" (EchoFlex) EEP 07-02-0C "Temp.Sensor, Window Contact" (EchoFlex) EEP 07-10-0A "Temp. Sensor, Set-Point Adj., Window Contact" (EchoFlex) EEP 07-30-02 "Window Contact, Single Input" (EchoFlex)
0.92		TR	Manufacturer ID: Guidelines added. Definitions updated Revision History moved to a separate document chapter INPUT document for Berlin Meeting April 2009
2.0R		TR	EEP 07-02-0C shifted to Room Operating Panels -> EEP 07-10-0B EEP 06-00-00 renamed to 06-00-01 EEP 05-xx-xx (PRS telegram / PTM200) updated with results of latest discussions EEP 05-04-01 (Key Card Activated Switch) updated Proposals Added: EEP 07-10-0C "Temp. Sensor, Occupancy Control" (Termokon) EEP 07-10-0D "Temp. Sensor, Day/Night Control" (Termokon) Ratification info and period added
2.0	July 2009		Creation of final Version V2.0 EEP 05-03-02 added EEP 05-04-01 corrected EEP 06-00-01 renamed Single Input Contact EEP 07-10-0A and EEP 07-10-0B updated Single Input Contact EEP 07-30-01 and EEP 07-30-02 updated Single Input Contact 4BS teach in Telegram updated FUNC /TYPE Editorial corrections
2.1R	Nov. 12, 2010	Op	The EEP 2.0 document as well as all 2.1 single documents were transferred to an XML data structure and standardized. The following chapters were re-written: Introduction, Teach-in, Bi-directional profiles, Smart Ack, RPC and MSC. Profiles that are still being coordinated were also accepted. These are characterized as 'Not approved' in the document. Bidirectional profiles are labeled with 'BI-DIR'. RPS ORG 05 = RORG F6; 1BS ORG 06 = RORG D5; 4BS ORG 07 = RORG A5
2.1.0R	Dec. 31, 2010	Op	2th review
2.1	Jan. 20, 2011	Op	Modifications of review